

Assembly Instructions for the *INCRA* Wheel Kit

Fig. 1 Wheel Kit

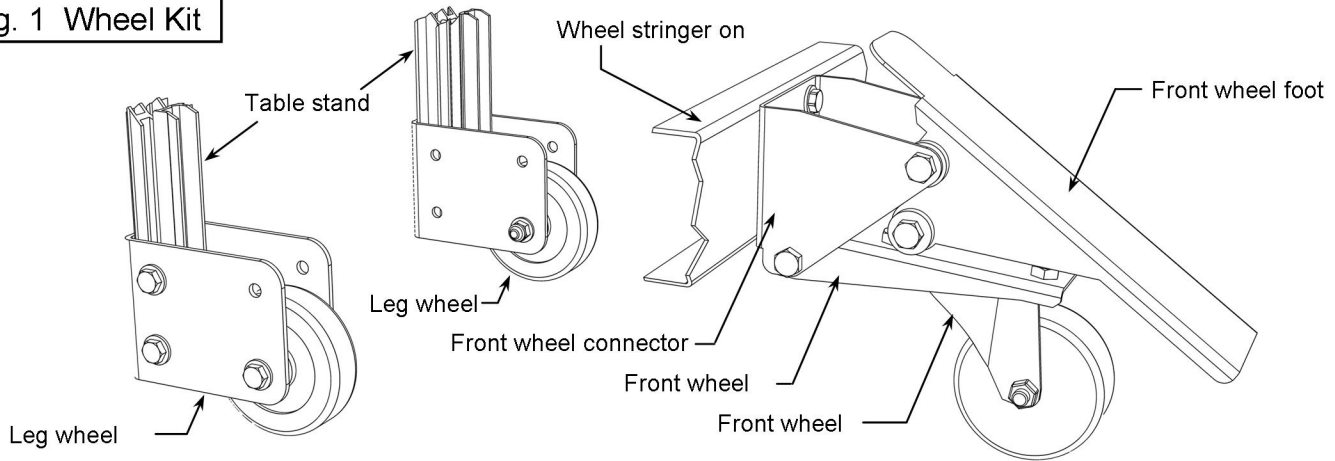

Parts List

- | | | |
|-----------------------------------|------------------------------|---------------------------------------|
| (1) Front wheel connector bracket | (12) 1/4-20 x 1/2 hex bolt | (6) 5/16-18 hex nut |
| (1) Front wheel pedestal | (2) 1/4-20 x 2 1/4 hex bolt | (2) 5/16-18 locking nut |
| (1) Front wheel foot pedal | (6) 5/16-18 x 1/2 hex bolt | (16) 1/4" flat washer |
| (1) Front wheel caster | (2) 5/16-18 x 3 3/4 hex bolt | (4) 1/4" lock washer |
| (2) Leg wheel bracket | (12) 1/4-20 SQUARE nut | (4) 1/4 id x 1/4 thick Nylon washer |
| (2) Leg wheel | (2) 1/4-20 locking nut | (4) 5/16 id x 3/16 thick Nylon washer |

Step 1. Assemble leg wheels.

First, loosley install four sets of 1/4-20 x 1/2 bolts, 1/4-20 square nuts and 1/4" washers in each wheel bracket as shown in **Fig. 2**. Second, install a rubber wheel in the lower hole on each wheel bracket using the 1/4-20 x 2 1/4 hex bolt, 1/4-20 locking nut, 1/4" steel washers and 1/4" thick Nylon washers as shown in **Fig. 2**. Be sure that the two 1/4" thick Nylon washers are against the hub of the wheel and positioned **INSIDE** the wheel bracket. Tighten the locking nut enough to remove all side play between the wheel and the inside of the wheel bracket, but still loose enough for the wheel to pivot freely.

Step 2. Install leg wheels on legs.

Orientation: When mounting the stand to offset tables, the two leg wheels should be located under the end of the table **WITH** the router cutout in it. For center mount router tables, the two leg wheels can be on either end of the table.

Remove the levelers from the two legs on which the wheels will be installed. As shown in **Fig. 3**, slide the (4) square nuts on each wheel assembly into the T-slots on the leg extrusion. Adjust the vertical position of each wheel for stability, then firmly tighten all bolts.

Fig. 2 Assemble leg wheels

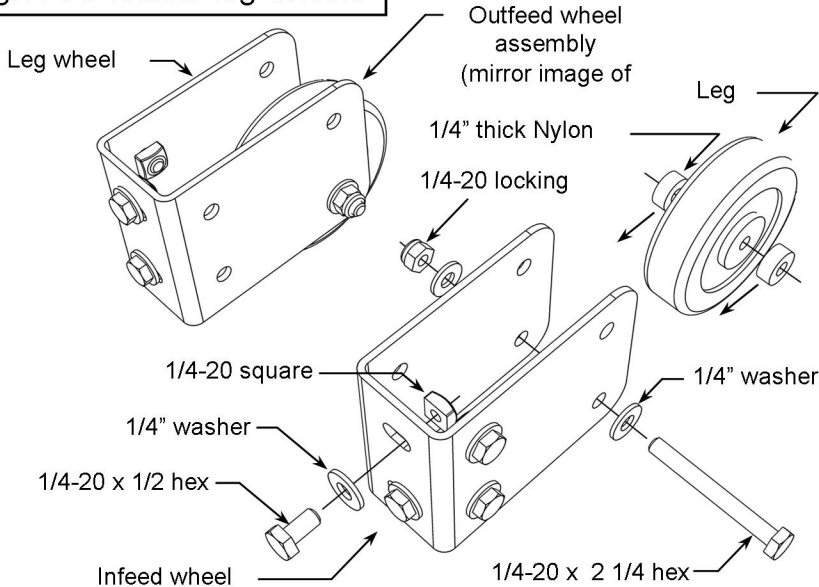
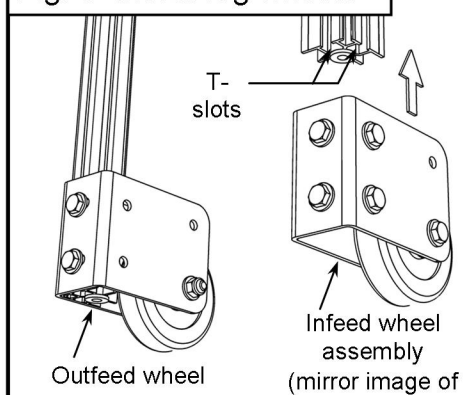

Fig. 3 Install leg wheels



INCRA® Made in America by:
Taylor Design Group, Inc.
www.incra.com PO Box 810262
Dallas, TX 75381
Phone: 972-242-9975

Step 3. Install connector bracket on wheel stringer.

Orient the front wheel connector bracket as shown in **Fig. 4**, then attach it to the wheel stringer using 1/4-20 x 1/2 hex bolts, 1/4" washers, 1/4" lock washers and 1/4-20 square nuts.

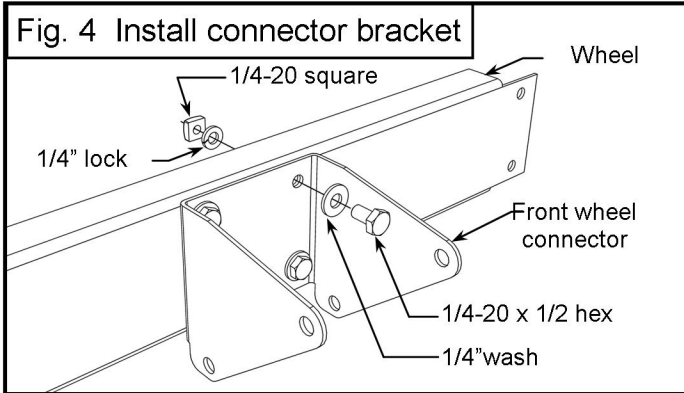

Step 4. Install caster on front wheel pedestal.

Using 5/16-18 hex bolts and 5/16-18 hex nuts, attach the swivel caster to the underside of the front wheel pedestal as shown in **Fig. 5**.

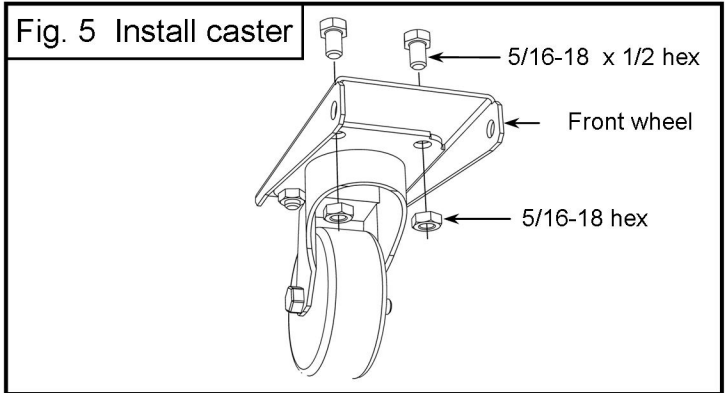

Step 5. Attach assembled front wheel pedestal to connector bracket.

Attach the assembled front wheel pedestal to the lower holes in the connector bracket by using a 5/16-18 x 3 3/4 hex bolt and 5/16-18 locking nut, **Fig. 6**. The front wheel pedestal must pivot freely. Do not over tighten.

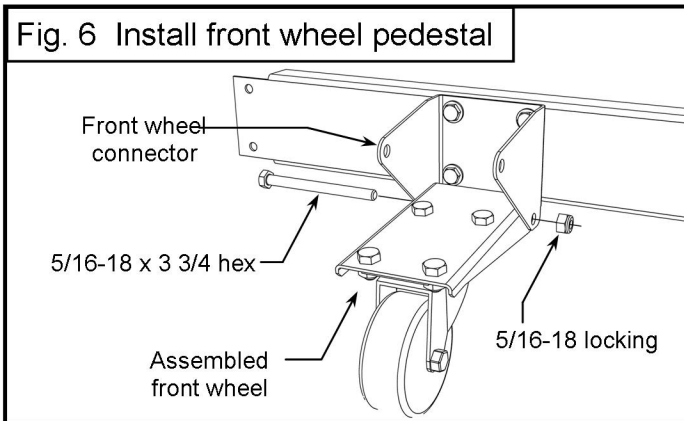

Step 6. Install NYLON washers on foot pedal.

Attach two of the 3/16" thick NYLON washers to the outside of the foot pedal using 5/16-18 x 1/2 hex bolts and 5/16-18 hex nuts through the holes indicated in **Fig. 7**. Tighten securely.

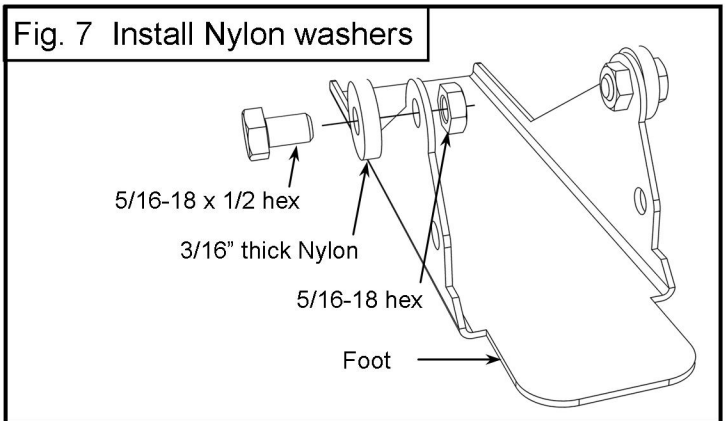

Step 7. Attach foot pedal to connector bracket.

Attach foot pedal to the upper holes in the connector bracket by using a 5/16-18 x 3 3/4 hex bolt, 5/16-18 locking nut and two 3/16" thick Nylon washers, **Fig. 8**. The foot pedal must pivot freely. **Do not over tighten.**

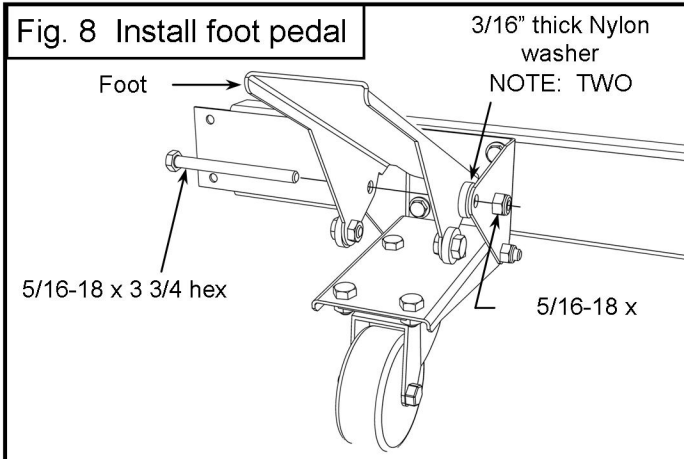

Step 8. Operation and adjustments.

Engage the swivel caster by pushing down on the front end of the foot pedal with your foot. Disengage the caster by pushing down on the other end of the foot pedal with your foot, **Fig. 9**.

