



## Operating Instructions and Parts Manual

### Mast-R-Lift

Models: 02101A and 02102A



JessEm Tool Company, LTD

100 Caplan Ave., Unit 14 & 15

Barrie, ON L4N 9J2 Canada

705-726-8233

705-726-7519 Fax

1-866-272-7492

[www.jessem.com](http://www.jessem.com)

[jessem@jessem.com](mailto:jessem@jessem.com)

Revised: 6/25/09

**Important!!**

**Read and understand the contents of this manual  
before assembly or operation of this product.**

Thank you for choosing this product from JessEm Tool Company. We appreciate your support and hope that our product serves you well. This product is designed to provide many years of reliable service provided it is used as intended and taken care of.

This user manual will assist you in assembly and general operation of this product. It is not our intent to teach you about woodworking. It is assumed that you are an experienced woodworker with the basic skills and experience necessary to use this product safely. If after reading the following instructions, if you are unsure or uncomfortable about safely using this product we urge you to seek additional information through widely available woodworking books or classes.

As part of our Continuous Product Improvement Policy, JessEm products are always advancing in design and function. Therefore there may be differences between what is shown in our catalogs, website or at retail display and what is sold at time of purchase. We reserve the right to make positive changes to our products at our discretion.

**Model 02101A – Fits Table Opening 9-1/4” x 11-3/4”**

**Fits Porter Cable 7518/7519 Router Motor**

**Model 02102A – Fit Table Opening 8-1/4” x 11-3/4”**

**This unit is for non-JessEm Router Tables**

**Adapter Collars for Model 02101A**

**Model 02111 – Fits Porter Cable 690/890, Bosch 1617/1618, DeWalt 610/616/618**

**Model 02113 (3-1/4” diameter) – Fits Makita 1101**

**Model 02115 – Fits Hitachi M12VC and KM12VC**

**Model 02118 – Fits Milwaukee 5615/5616/5619**

**Shim Kit Model 02116 – Fits Milwaukee 5625**

## IMPORTANT SAFETY PRECAUTIONS

- Before operating any router, read and understand all safety instructions in the owner's manual that came with the router.
- If you do not have a manual, contact the manufacturer and obtain one before using any power tool.
- Always wear eye protection in compliance with ANSI safety standards when operating any power tool.
- Always use proper guards and safety devices when operating power tools and machinery.
- Carefully check router bits before each use. Do not use if damage or defect is suspected.
- Do not exceed the recommended RPM for any router bit.
- Do not wear loose clothing or jewelry that may catch on tools or equipment.
- Unplug the tool or machine when mounting or making any adjustments to mechanical performance.

**DO NOT USE A CORDLESS DRILL TO RAISE AND LOWER THE LIFT CARRIAGE. THE AMOUNT OF FRICTION WILL CAUSE PREMATURE WEAR OF THE THREADS.**

## ROUTER SAFETY PRECAUTIONS

- Never force the bit or overload the router beyond the expectations of the tool.
- Be sure that at least 3/4 of the shank length is inserted securely in the router collet.
- Never bottom out the bit in the collet. Allow 1/8" clearance between shank and bottom of collet.
- Always make sure the fence on your router table is locked into position before each use.
- Always rout in two or more passes when large amounts of stock must be removed.
- Use reduced RPM speeds for large diameter bits.

### CALIFORNIA PROPOSITION 65 WARNING

This product contains lead known to the State of California to cause cancer or reproductive harm. Components made of brass are known to contain lead. Wash hands after using this product.

## **Suggested Router Bit Speeds**

<u>Bit Diameter</u>	<u>Max. Speed</u>
1" (25mm)	24,000 RPM
1-1/4" - 2" (30-50mm)	18,000 RPM
2-1/4" - 2-1/2" (55-65mm)	16,000 RPM
3" - 3-1/2" (75-90mm)	12,000 RPM

## **JessEm Tool Company Limited Warranty**

All JessEm products are warranted to be free from defects in material and workmanship. JessEm will repair or replace any product which upon inspection proves to be defective for a period of (1) year from dated receipt and proof of purchase. All warranty claims should be made direct to JessEm Tool Company. Contact JessEm for a warranty claim return authorization and instructions to proceed. The consumer is responsible for shipping costs to return product to JessEm Tool Company. We will repair or replace the product at our discretion and JessEm Tool will return shipment to you at no charge.

## **Warranty Limitations**

This warranty does not cover:

- Repairs or alterations made or attempted by anyone other than JessEm Tool Company or an authorized JessEm service professional.
- Normal wear and tear
- Abuse, misuse or neglect.
- Improper care or maintenance.
- Continued use after partial failure.
- Products that have been modified in any way.
- Products used with improper accessories.
- Premature thread wear due to adjusting height with electric or cordless drill

## **CONTENTS:**

(1) Mast-R-Lift, (1) Height Adjustment Handle, (1) Insert Ring, (1) Insert Ring Wrench, (1) Hex Key, (1) Start Pin

**TOOLS REQUIRED FOR ASSEMBLY:** 6mm and 8mm Hex Key

**TOOLS REQUIRED FOR ADJUSTMENT:** 10mm Wrench

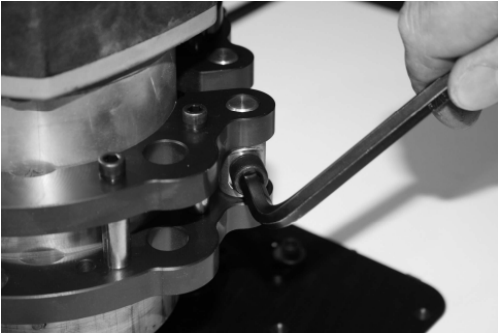

**Figure 1**

### **Installing the Router**

Place the crank handle into the hex hole in the lift's dial on the top plate. Crank the lift carriage up so that it just contacts the O-rings at the top of the carriage shafts. The carriage should be all the way toward the top plate. With a 5/16" hex wrench, loosen the cap screw on the carriage clamp to allow the motor to slide into the carriage assembly (Fig. 1). The Mast-R-Lift will accept the Porter Cable 7518 out of the box. If you are using a smaller diameter router motor insert the adapter collar into the opening.

Before installing the router motor, prop the unit up on blocks of wood (Fig. 2) so the router's collet can extend through the center hole in the top plate. The motor housing must slide all the way through and contact the inside back of the center hole on the plate.

Now slide the router motor into the carriage so the top of the motor housing just makes contact with the inside surface of the center hole in the top plate.

### **Installing the Router (cont'd)**

Rotate the router so that when the final installation is made all router controls will be positioned for convenient access. Then back the motor off approx. 1/16" from contacting the top plate and tighten the cap screw on the carriage assembly.

### **Installing a JessEm Lift in a Custom Router Table Application**

A JessEm router lift is similar to using a router mounting plate. Your table top must have a port machined into the top. JessEm offers solid phenolic router tables tops with pre-machined ports for all JessEm router lifts. If you are installing this Lift in a custom table application you will have to fabricate this opening yourself. JessEm offers a separate template for this operation. See your JessEm distributor for the proper template for your JessEm router lift.



**Figure 2**

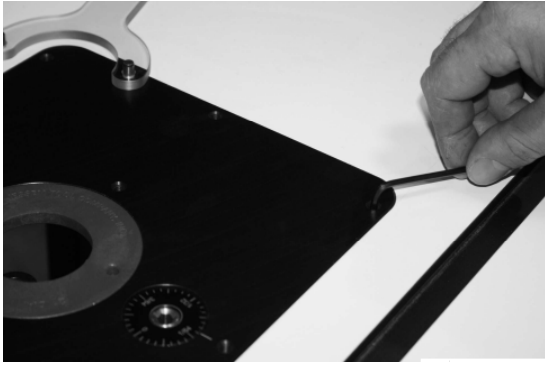

**Figure 4**

### **Leveling the Lift to the Table Top**

The Mast-R-Lift features 8 drilled and tapped holes around the perimeter of the insert plate with adjustable set screws (Fig. 4). Using the hex wrench included with your lift, turn the set screws in the clockwise direction to raise the insert plate or turn the set screws in the counter clockwise direction to lower the insert plate until the insert plate is level (flush) with the router table surface. Start at one corner of the insert plate and work your way around the perimeter of the insert plate until all set screws have been adjusted properly so that the insert plate does not rest above or below the table surface. Once the insert plate has been leveled properly, please see figure 4 for adjusting the insert plate to the table.

### **Securing the Mast-R-Lift to the Table**

After adjusting the leveling screws and getting the lift plate level and flush with the table top, the Mast-R-Lift can be secured by inserting a bolt through the top of the lift then screwing the bolt into the corresponding corner hole in the table opening using a hex key (Fig. 5). This will secure the lift or plate from moving during operation. Refer to the router lift or plate manual for more details on leveling the lift or plate to the table.



**Figure 5**

### **Tab-Loc Insert Rings**

The Rout-R-Lift FX comes with one insert ring with a pre-drilled 1-1/2" diameter center hole. Additional ring sets are available with different diameter pre-drilled holes and/or no pre-drilled holes for creating your own custom center hole diameters. See your JessEm distributor for these and other accessories.



**Figure 6**

1. Place the insert ring into the center hole of the Lift's top plate (Fig. 6).
2. With the insert wrench provided, insert the prongs of the wrench into the corresponding holes in the insert ring and turn the insert ring counter clockwise to tighten.
3. Turn the insert wrench clockwise to loosen and remove the ring. If the insert ring becomes too tight to loosen with hand pressure, a tap clockwise on the insert wrench with a block of wood will loosen it.

## Using the Mast-R-Lift

To raise your router, turn the height adjustment handle clockwise. To lower, turn the handle counter-clockwise. Keep in mind that one complete revolution equals 1/16" of change. When your adjustment is complete, remove the handle and place somewhere off the work surface for safety. Refer to the chart below for fractional and decimal adjustments based on amount of revolutions made.

<u>Fraction</u>	<u>Decimal</u>	<u>Number of Revolutions</u>
1/64"	0.016"	1/4
1/32"	0.031"	1/2
1/16"	0.062"	1 Revolution
1/8"	0.125"	2
1/4"	0.250"	4
1/2"	0.500"	8

## Re-Adjusting the Thread Tensioning

All JessEm Lifts feature our patented thread tensioning design. This feature is why it is not necessary to lock the router into position after setting the cutting height. The design keeps tension on the position wherever you set the height. Thread tension is set at the factory and depending on the amount of use you may have to reset this adjustment periodically. If the bit height ever begins to change (or drop) during use, the thread tensioning likely needs to be reset.

1. Turn the Lift upside down on a table with the threaded height adjustment rod facing you.
2. With an open end wrench, (Fig. 7) loosen the hex nut that is located on the right side of the brass post next to the threaded rod. Then use a hex wrench to back out the set screw that threads through the nut until the brass tensioning collar can be turned.



Figure 7

3. Then route the brass tensioning collar (Fig. 8) with vertical grooves, so it tightens against the rubber washer. Note: A drop of oil on the rubber washer eases the rotation of the brass collar.
4. Make certain the set screw seats in one of the vertical grooves when tightening the brass collar.
5. Tighten the nylon lock nut with the open end wrench again and the adjustment is complete.

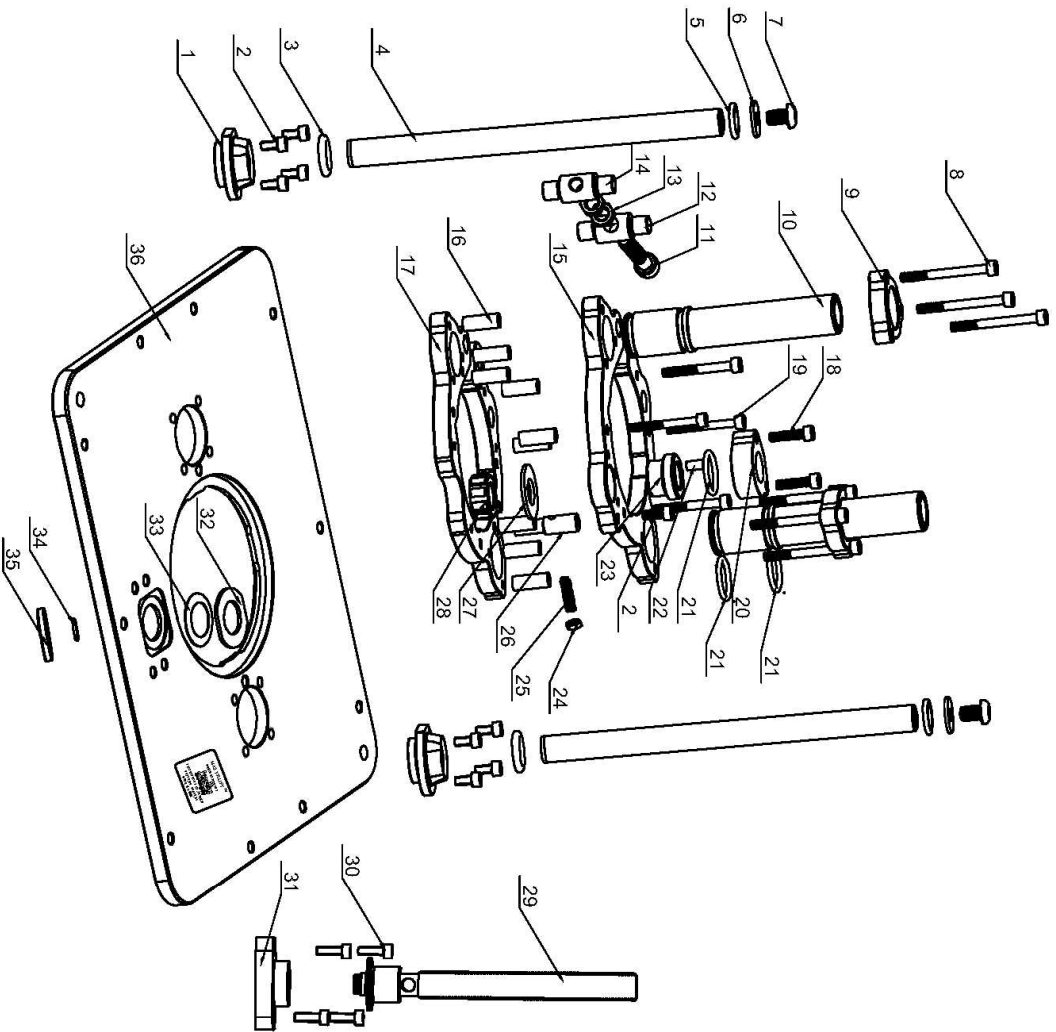

Figure 8

## 02101A Mast-R-Lift Parts List

Item No.	Part No.	Description	Qty	Specification
1	02101A-001	Guide Tube Base	2	
2	02101A-002	Shaft Mtg Block Bolt	9	M6X12
3	02101A-003	Rubber O-ring	2	M29.4X18.6X5.4
4	02101A-004	Bearing Tube	2	
5	02101A-005	Rubber O-ring	2	M25.4X18.6X3.4
6	02101A-006	washer	2	M8.5X25X2.5
7	02101A-007	Screw	2	M8X16
8	02101A-008	Carriage Bolt long	6	M6X63
9	02101A-009	Carriage Tube Retainer	2	
10	02101A-010	Guide Tube	2	
11	02101A-011	Carriage Lock bolt	1	M10X60
12	02101A-012	Clamp pin	1	
13	02101A-013	Carriage Adjusting Lock Nut	2	M10
14	02101A-014	Clamp pin	1	
15	02101A-015	Down carriage plate	1	
16	02101A-016	Carriage Spacer	10	
17	02101A-017	Upper Carriage Plate	1	
18	02101A-018	Retainer Bolt	2	M6X25
19	02101A-019	Carriage bolt short	4	M6X50
20	02101A-020	Retainer	1	
21	02101A-021	Rubber O-ring	3	M32X25.2X3.4
22	02101A-022	Pin	1	
23	02101A-023	Shaft Bushing	1	
24	02101A-024	Backlash Lock Nut	1	M6
25	02101A-025	Backlash set screw	1	M6X25
26	02101A-026	Backlash Pin	1	
27	02101A-027	Rubber Washer	1	
28	02101A-028	Brass Backlash Nut	1	
29	02101A-029	Lead Screw w/spring pin	1	
30	02101A-030	Mtg Block Bolt	4	M6X18
31	02101A-031	Spindle Mounting Block	1	
32	02101A-032	Brass Washer	1	
33	02101A-033	Spring Washer	1	
34	02101A-034	Rubber Washer	1	
35	02101A-035	Height Dial	1	
36	02101A-036	Top Plate	1	
A	02101A-A	2" Insert Ring	1	
B	02101A-B	Hex Key	1	M6
C	02101A-C	Hex Key	1	M8
D	02101A-D	Starter Pin	1	
E	02101A-E	Leveling Screw	11	M6X8
F	02101A-F	Crank Handle	1	
G	02101A-G	Wrench	1	





**02101A Explode View**

