

## Operation

To use your new INCRA Right Angle Fixture, position the guide hook on the infeed end of your fence and lock in place using the middle tensioning screw. Position the stock to be cut against the faceplate. Make sure that the edges of the boards are against the fence and the ends are contacting the table surface, then clamp in place using a wooden handscrew clamp or C-clamp. Loosen the middle tensioning screw and you are ready to make the cut. See Fig. 5.

**Caution:** *Do not* allow any part of your hands to hang below the aluminum base of the Right Angle Fixture. Always keep hands well away from the bit.

To avoid contacting the wooden runners on your Right Angle Fixture with the router bit, place an INCRA Stop or a wooden stop block on the outfeed end of your fence to stop the forward travel of the Right Angle Fixture before contact. See Fig. 6.

## Mounting an Auxiliary Faceplate

The T-slot design of your INCRA Right Angle Fixture permits the attachment of an auxiliary faceplate if desired. This faceplate may simply be a flat piece of  $1/2"$  or  $3/4"$  stock used to provide additional support and clamping area for handling large stock, or it may be a special holding fixture of your design to help in securing irregular shaped pieces. Drill and counterbore your custom made faceplate to match the locations of the T-slots and use #10-32 machine screws, #10 washers, and the supplied #10-32 rectangular nuts to attach the face plate to your INCRA Right Angle Fixture. The length of the #10-32 machine screws will vary according to the thickness of your faceplate. Fig. 7 shows the hole/counterbore dimensions and screw length necessary for use with  $1/2"$  or  $3/4"$  thick faceplates.

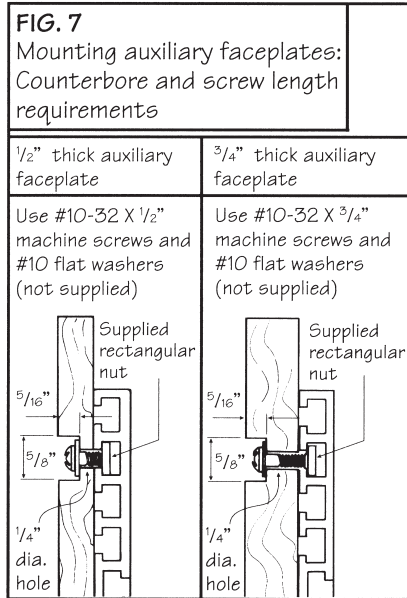
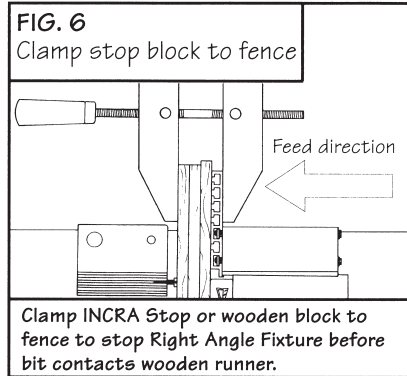
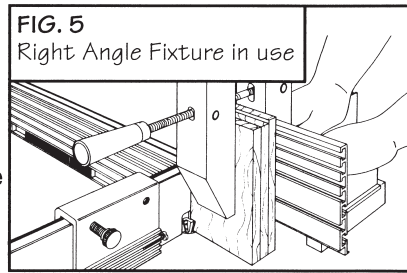

# INCRA® Right Angle Fixture

Use your new INCRA Right Angle Fixture to hold stock perpendicular to the table surface for various cutting operations at the router table. The guide hook glides along the top of your INCRA Fence for smooth and accurate tracking throughout the full range of movement, and the unique T-slot design provides an efficient means by which you can attach auxiliary faceplates and clamping or positioning aids to suit your needs.

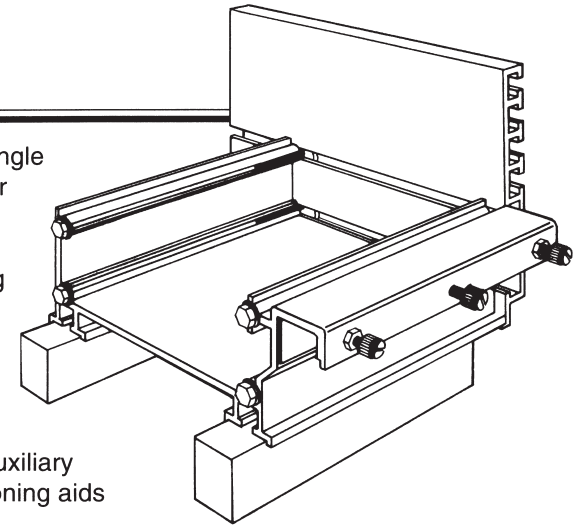

## Safety

The following are important safety instructions for using the INCRA Right Angle Fixture. Before using the INCRA Right Angle Fixture, read and follow all of the instructions and safety information in this manual.

- When using the INCRA Right Angle Fixture in conjunction with any other tool, first read and follow all instructions and safety information in that tool's owner's manual.
- USE APPROPRIATE SAFETY DEVICES. Keep hands clear of the bit or blade. Always use a push stick, rubber soled push block, or other safety device to keep your hands safely away from the cutting tool.
- NEVER let any part of the INCRA Right Angle Fixture interfere with another tool's safety guards or other safety equipment.
- NEVER let the bit or blade come in contact with the aluminum body of the INCRA Fence, INCRA Stop, or INCRA Right Angle Fixture.
- ALWAYS turn off the power and make sure that the bit or blade is fully stationary before changing the setting of any part of the INCRA Jig, INCRA Fence, INCRA Stop, Stop Extender Bar, or INCRA Right Angle Fixture.
- Wear safety glasses and hearing protection.
- Follow all normal shop safety practices.
- NEVER attempt to hold your work to the INCRA Right Angle Fixture using your hands alone. Always use a clamp or other suitable holding device to securely hold your work to the front face of the fixture. Never let any part of the clamping device come in contact with the bit or blade.
- Keep hands above the aluminum base of the INCRA Right Angle Fixture at all times. Never let your hands dangle below, or stray beyond the sides of the aluminum base.
- Never let the bit or blade come in contact with the wooden runners on your INCRA Right Angle Fixture. Always clamp an INCRA Stop or wooden block to the outfeed end of the fence to stop the forward motion of the Right Angle Fixture before the bit contacts the wooden runners.

## WARRANTY

Taylor Design warrants this product for one year from date of purchase. We will repair any defects due to faulty material or workmanship or at our option, replace the product free. Please return the failing part only, postage prepaid, along with a description of the problem to the address below. This warranty does not apply to parts which have been subjected to improper use, alteration, or abuse.  
**Taylor Design Group, Inc., P.O. Box 810262, Dallas, TX 75381** IRAF-RV0695  
 © 1995, Taylor Design Group, Inc. INCRA is a registered trademark of Taylor Design Group, Inc.

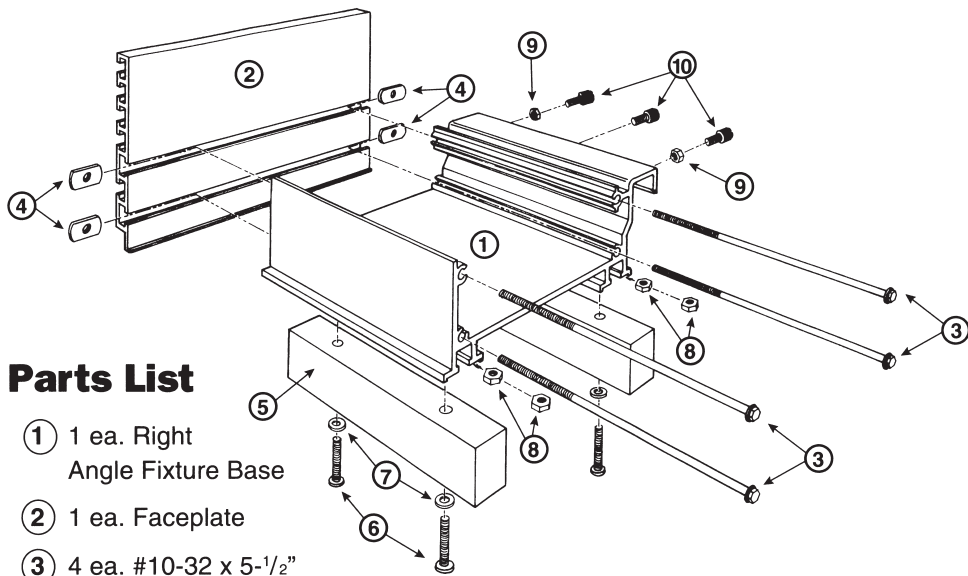

## Parts List

- ① 1 ea. Right Angle Fixture Base
- ② 1 ea. Faceplate
- ③ 4 ea. #10-32 x 5-1/2" hex bolts
- ④ 8 ea. #10-32 rectangular nuts
- ⑤ 2 ea. 14-ply wooden runners
- ⑥ 4 ea. #10-32 x 1-1/4" phillips machine screws
- ⑦ 4 ea. #10 flat washers
- ⑧ 4 ea. #10-32 hex nuts
- ⑨ 2 ea. #10-32 nylon hex nuts
- ⑩ 3 ea. #10-32 x 1/2" nylon thumb screws

## Assembly

**1** Attach the faceplate to the INCRA Right Angle Fixture base using the (4) #10-32 x 5-1/2" hex bolts and rectangular nuts. Insert the bolts through the base and loosely attach the (4) rectangular nuts. Now slide the rectangular nuts into the T-slots in the faceplate. Make sure the two surfaces marked with a "x" in Detail 1A are aligned flush. Tighten the hex bolts.

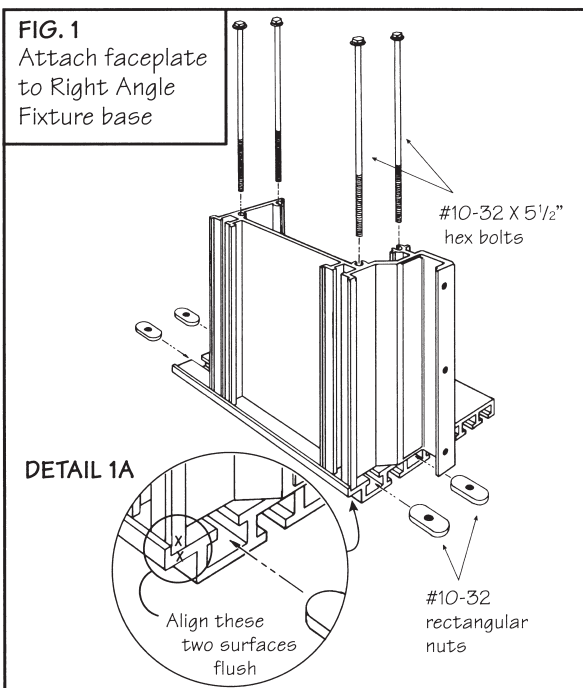

**2** Attach the two wooden runners to the bottom of your Right Angle Fixture base using the (4) #10-32 x 1-1/4" machine screws, #10 flat washers and #10-32 hex nuts. Make sure to place a washer on each screw before inserting through the holes in the runner. Each runner should extend about 1/2" beyond the rear of the base. See Fig. 2.

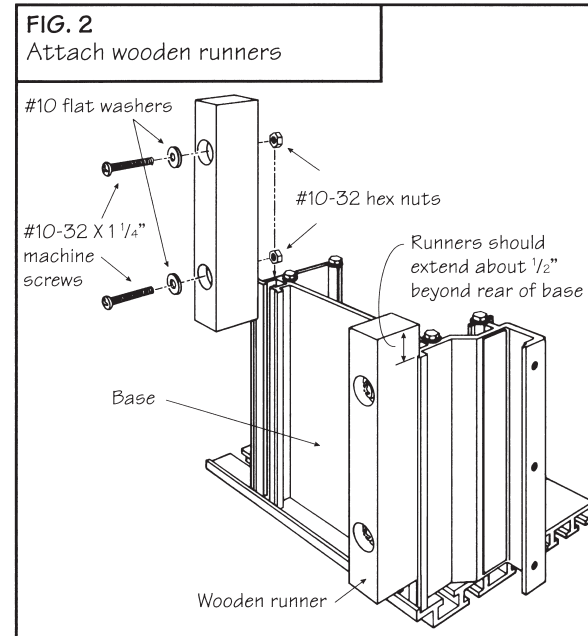

**3** Thread the two nylon hex nuts onto two of the three guide tensioning screws and then insert the screws into the threaded holes on the guide hook side of the base. The tensioning screw without a locking nut goes in the middle hole. See Fig. 3.

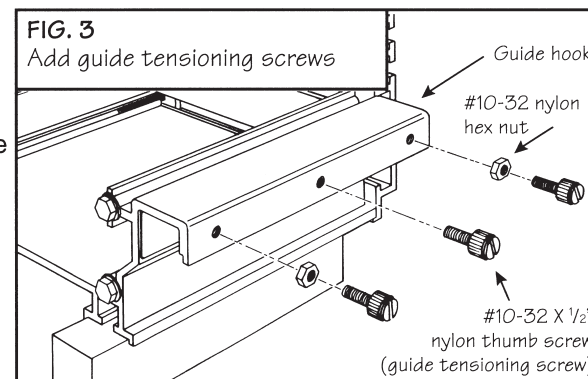

## Guide Tensioning Screws

Place the INCRA Right Angle Fixture on your INCRA Fence and adjust the two outside tensioning screws to allow smooth tracking along the fence. See Fig. 4. The middle tensioning screw is used *only* when you wish to lock the INCRA Right Angle Fixture to your fence. Immobilizing the Right Angle Fixture with the middle tensioning screw is helpful when clamping stock to the faceplate.

