

Incra[®]

Micro Precision Table Saw Fence™



The only table saw fence with Automatic Positioning Control™

OWNER'S MANUAL

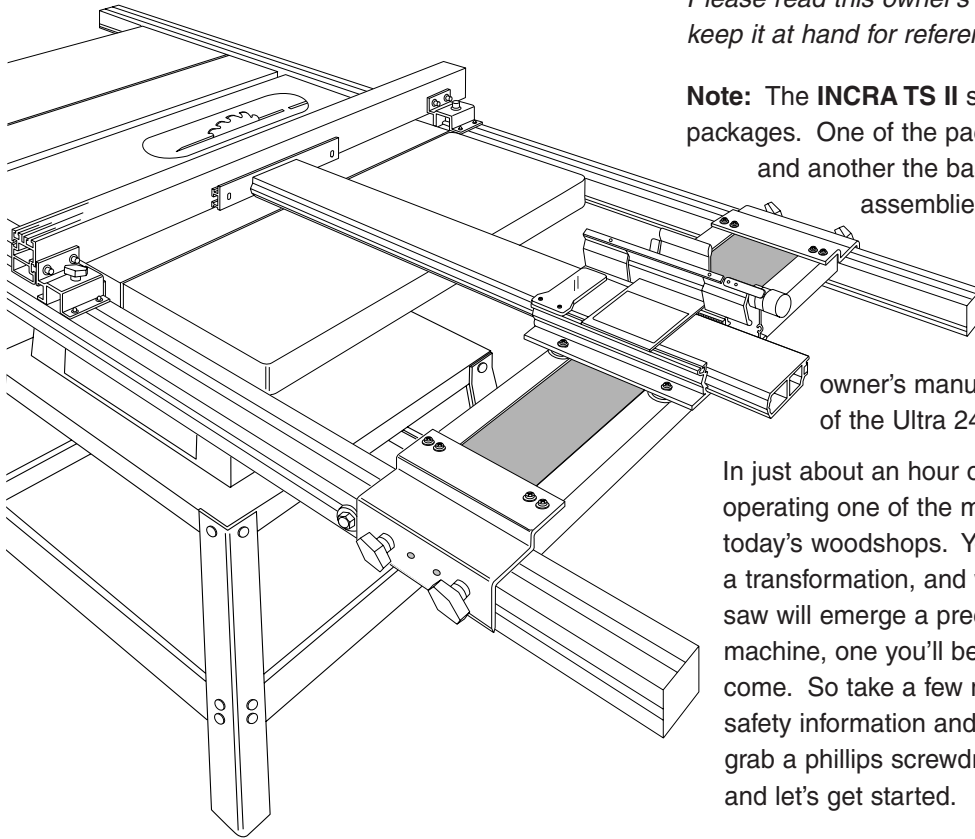

Please read this owner's manual before use and keep it at hand for reference.

Note: The **INCRA TS II** system consists of three packages. One of the packages contains the rails and another the base mount unit. These two assemblies are covered fully by this owner's manual. The third package contains the **INCRA Jig Ultra 24**. Read all of this **TS II** owner's manual and pages 2, 3, 6 and 7 of the **Ultra 24** owner's manual.

In just about an hour or so, you are going to be operating one of the most exciting new tools in today's woodshops. Your table saw will undergo a transformation, and what was once an average saw will emerge a precision woodworking machine, one you'll be proud of for years to come. So take a few minutes to read over the safety information and mounting instructions, then grab a phillips screwdriver and a set of wrenches and let's get started.

CONTENTS

Safety	2	Blade Guard Adjustments	11
Fasteners and Hardware Lists	2	Extension Table	11
Rail Assembly	4	Auxiliary Fence Mounting	12
Base Mount Assembly	6	Maintenance	12
Fence Assembly	8	Product Information	12
Final Calibration	9	Warranty	12

SAFETY

Important safety instructions for using the INCRA TS II.

- Before using the INCRA TS II, read and follow all of the instructions and safety information in this manual.
- When using the INCRA TS II in conjunction with any other tool, first read and follow all instructions and safety information in that tool's owner's manual.
- Never let any part of the INCRA TS II interfere with another tool's safety guards or other safety equipment.
- Before using your INCRA TS II, make sure all mounting screws are tight and that the black clamping knobs are securely tightened to the rails.
- Always turn off the power and make sure that the blade is fully stationary before changing the setting on any part of the INCRA TS II.
- Always keep both hands behind the fence when moving the INCRA TS II to a new setting.
- Before making a cut, always make sure that the carriage clamp is fully engaged and that the rail hook thumbscrew is securely tightened.
- Use appropriate safety devices. Keep hands clear of the saw blade! Always use a push stick, rubber soled push block, or other safety devices to keep your hands safely away from the saw blade.
- Never let the saw blade come into contact with any part of the INCRA TS II or INCRA Jig Ultra.
- Wear safety glasses, hearing protection, and follow all normal shop safety practices.
- Never operate your table saw without a blade guard.

FASTENERS (actual size)

Mounting Bracket Hardware Pack

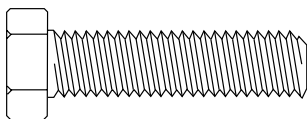

3/8 – 16 x 1 1/2"
hex bolt

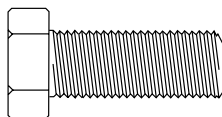

3/8 – 24 x 1"
hex bolt

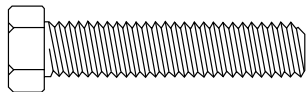

5/16 – 18 x 1 1/2"
hex bolt

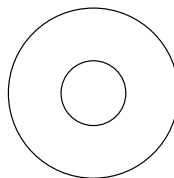

3/8"
flat washer

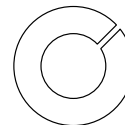

3/8"
lock washer

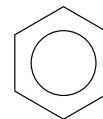

3/8 – 16
hex nut

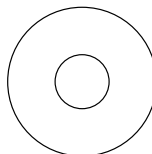

5/16"
flat washer



5/16"
lock washer

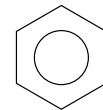

5/16 – 18
hex nut

Contents:

- | | |
|--|------------------------------|
| 6 ea. 3/8-16 x 1 1/2" hex bolt | 4 ea. 5/16" flat washer |
| 4 ea. 5/16-18 x 1 1/2" hex bolt | 6 ea. 3/8" lock washer |
| 2 ea. 3/8-24 x 1" hex bolt (Delta Unisaw) | 4 ea. 5/16" lock washer |
| 6 ea. 3/8" flat washer | 6 ea. 3/8-16 hex nut |
| | 4 ea. 5/16-18 hex nut |

Note: Extra hardware is provided in this pack to ensure compatibility with a wide variety of table saws. Only four of the bolts will be used in a typical installation.

Rail Hardware Pack

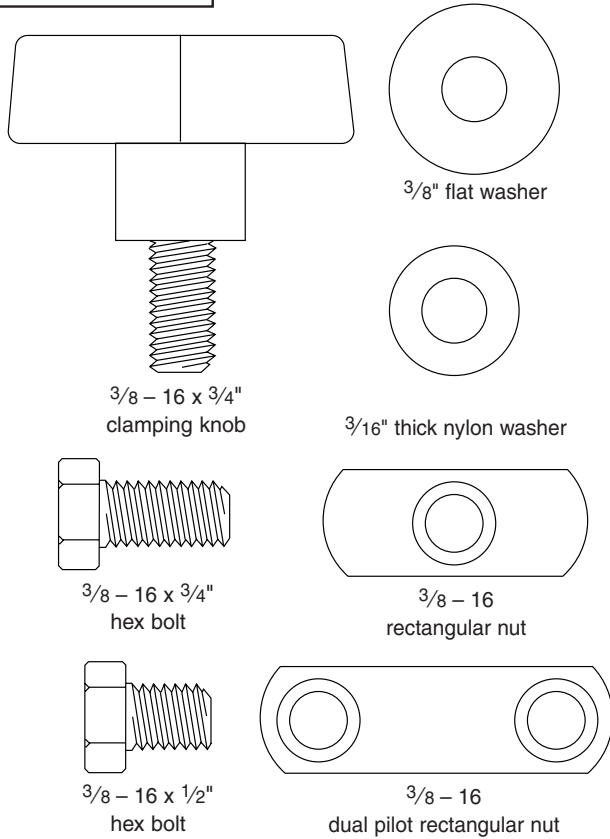

Contents:

- 4 ea. 3/8-16 x 3/4" clamping knob
- 6 ea. 3/8-16 x 3/4" hex bolt
- 4 ea. 3/8-16 x 1/2" hex bolt
- 10 ea. 3/8" flat washer
- 4 ea. 3/16" thick nylon washer
- 10 ea. 3/8-16 rectangular nut
- 8 ea. 3/8-16 dual pilot rectangular nut
- 8 ea. 3/8-16 x 3/8" socket head set screw



3/8 - 16 x 3/8" socket head set screw

Base Mount and Fence Glide Hardware Pack

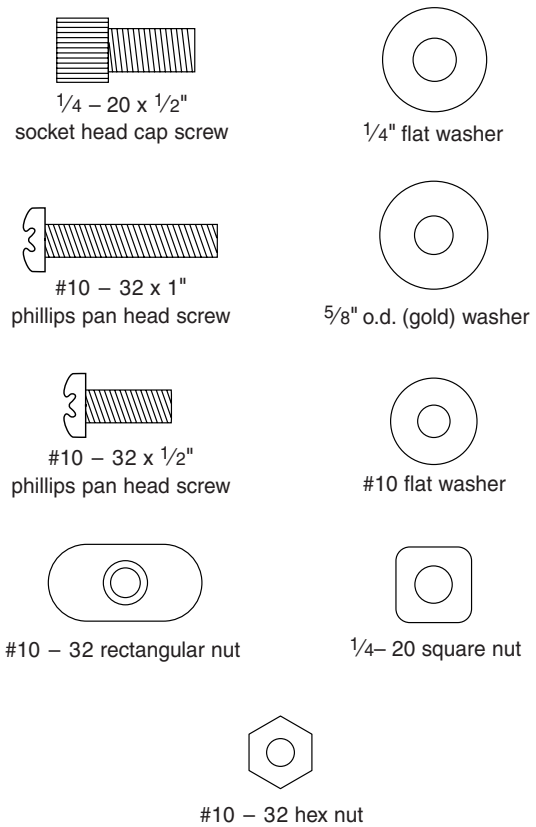

Contents:

- 4 ea. 1/4-20 x 1/2" socket head cap screw
- 2 ea. #10-32 x 1" phillips pan head screw
- 8 ea. #10-32 x 1/2" phillips pan head screw
- 2 ea. #10-32 rectangular nut
- 4 ea. 1/4" flat washer
- 2 ea. 5/8" o.d. (gold) flat washer
- 8 ea. #10 flat washer
- 4 ea. 1/4-20 square nut
- 8 ea. #10-32 hex nut

ULTRA Mounting Hardware Pack

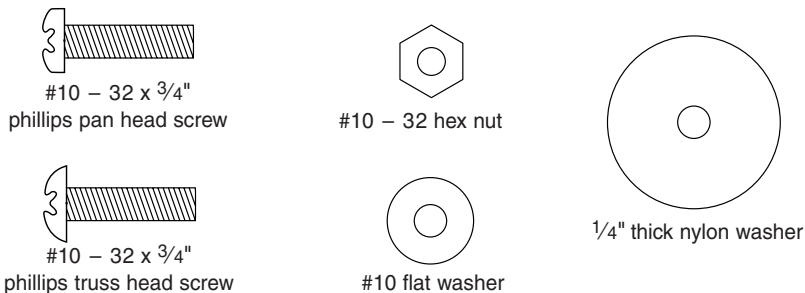

Contents:

- 4 ea. #10-32 x 3/4" phillips pan head screw
- 2 ea. #10-32 x 3/4" phillips truss head screw
- 6 ea. #10-32 hex nut
- 4 ea. #10 flat washer
- 6 ea. 1/4" thick nylon washer

RAIL ASSEMBLY

Unplug your table saw and remove the existing fence, including the front and rear support rails, mounting brackets, and the blade guard.

Note: The blade guard must be reinstalled after you have finished mounting the INCRA TS II to your table saw.

1 Attach mounting brackets

Attach (4) mounting brackets to the cast iron surface of your table saw using the supplied hardware. See **Fig. 1**. The Mounting Bracket Hardware Pack contains a variety of fasteners which will work with most table saws. Use the largest bolts in the pack that will fit your saw's existing mounting holes. If the holes in your table saw are threaded, use the bolt/washer arrangement shown in **Detail 1A**. If the mounting holes are not threaded, use the bolt/washer/nut arrangement shown in **Detail 1B**. Position the mounting brackets $\frac{1}{4}$ " below the table top as shown in **Details 1A** and **1B** and snug the fasteners to hold the brackets in place. **DO NOT TIGHTEN THE BOLTS AT THIS TIME.** (Discard any remaining fasteners from the Mounting Bracket Hardware Pack.)

FIG. 1

Attach rail mounting brackets

Use appropriate mounting hardware from the Mounting Bracket Hardware Pack to attach brackets (See Details 1A and 1B)

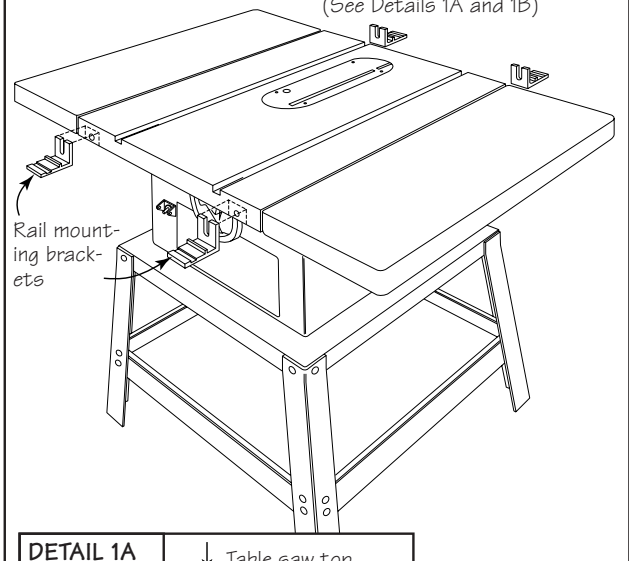

DETAIL 1A

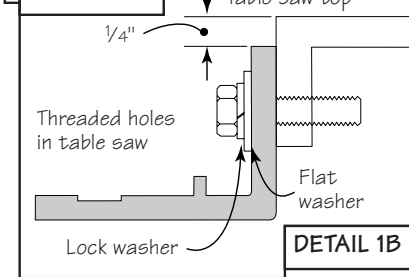

DETAIL 1B

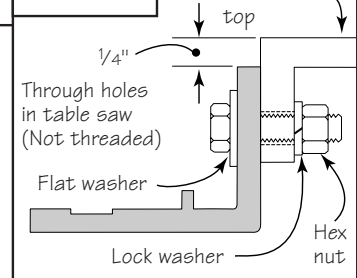
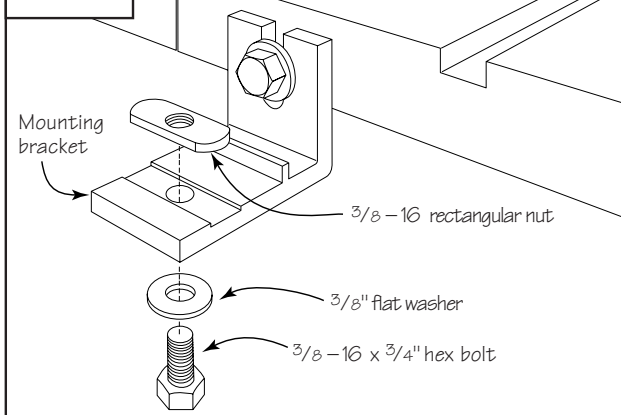

FIG. 2

Loosely attach rail bolts



2 Loosely attach rail bolts

Open the Rail Hardware Pack. Add a $\frac{3}{8}$ " flat washer to each of (4) $\frac{3}{8}$ -16 x $\frac{3}{4}$ " hex bolts. Place the bolts through the holes in the mounting brackets and loosely attach the $\frac{3}{8}$ -16 rectangular nuts. See **Fig. 2** above.

3 Slide rails onto mounting brackets and tighten bolts

Carefully slide the rails onto the mounting brackets so that the rectangular nuts are captured in the T-slot on the bottom of the rail. **Fig. 3** shows the correct orientation for the front and back rails. Approximately center the length of the rails on your table saw and tighten the mounting bolts that secure the rails to the brackets.

FIG. 3

Front and rear rail orientation

Orient rails so that web is vertical and off center T-slot faces the saw as shown below

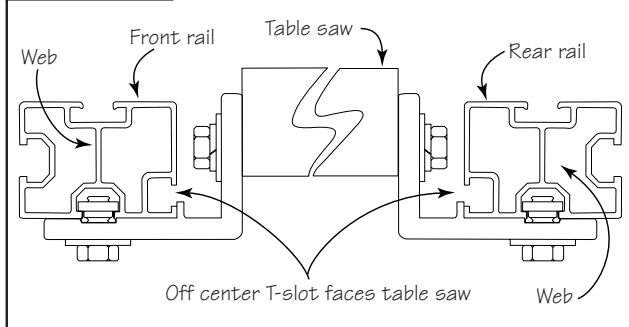

4 Set final mounting bracket position

Clamp the (2) TS II base clamps to the front rail as shown in Fig. 4 and loosen the bolts that secure the mounting brackets to your table saw. The rail and mounting brackets will drop down until the base clamps touch the top of your saw, Fig. 5. This locates the final mounting bracket position. Tighten the bolts that secure the mounting brackets to your table saw. Repeat for the rear rail.

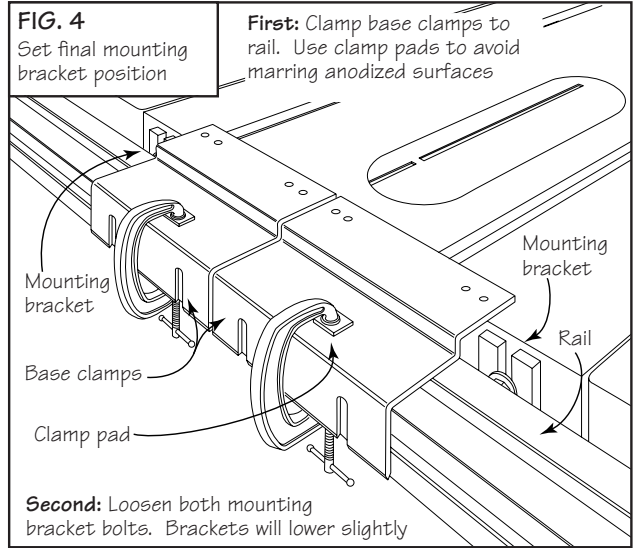
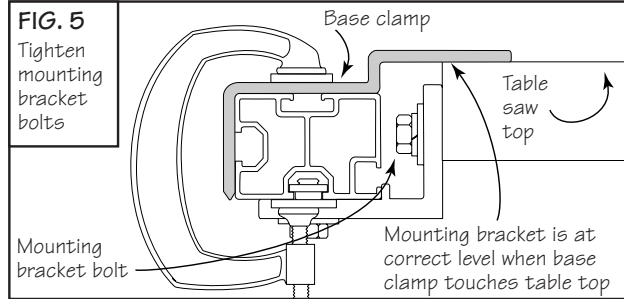

5 Set final rail position

Loosen the bolts that secure the rails to the mounting brackets and slide the rails so that they extend 7" beyond the left hand extension wing of your table saw as shown in Fig. 6. Push the rail against the short vertical leg on the mounting bracket and tighten the bolts that hold the rail in place. See Fig. 7 below.

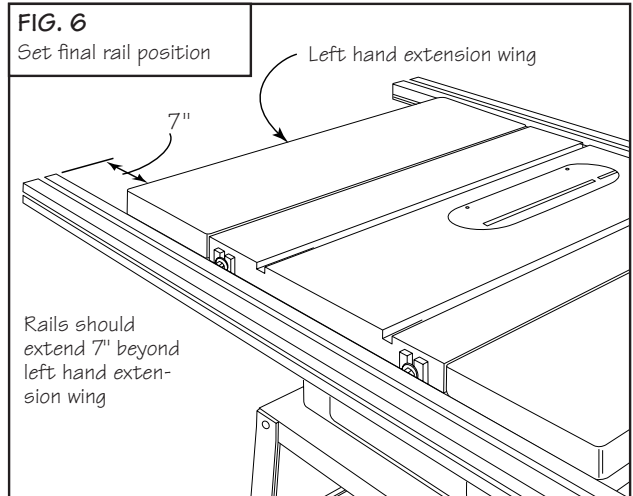
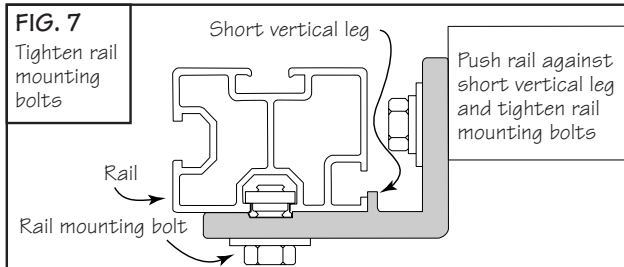

6 Slide stop positioner and base clamping knob assemblies onto the rails

Stop positioner - Add a 3/8" flat washer to each of (4) 3/8-16 x 1/2" hex bolts, then loosely attach a 3/8-16 rectangular nut. Slide one stop positioner into each end of both rails, capturing the rectangular nut in the T-slot facing away from the saw. Do not tighten bolt at this time.

Base clamping knob - Add a 3/16" thick nylon washer to each of (4) base clamping knobs and loosely attach a 3/8-16 dual pilot rectangular nut. The flat side of the rectangular nut should face the knob. Thread a 3/8-16 x 3/8" set screw into the remaining hole on each rectangular nut. Slide the base clamping knob assemblies onto the right hand end of each rail as viewed from the operator's side of the table saw. Thread a 3/8-16 x 3/8" set screw into the remaining (4) dual pilot rectangular nuts and slide into the left hand end of each rail. Do not tighten set screws or knobs at this time. See Fig. 8.

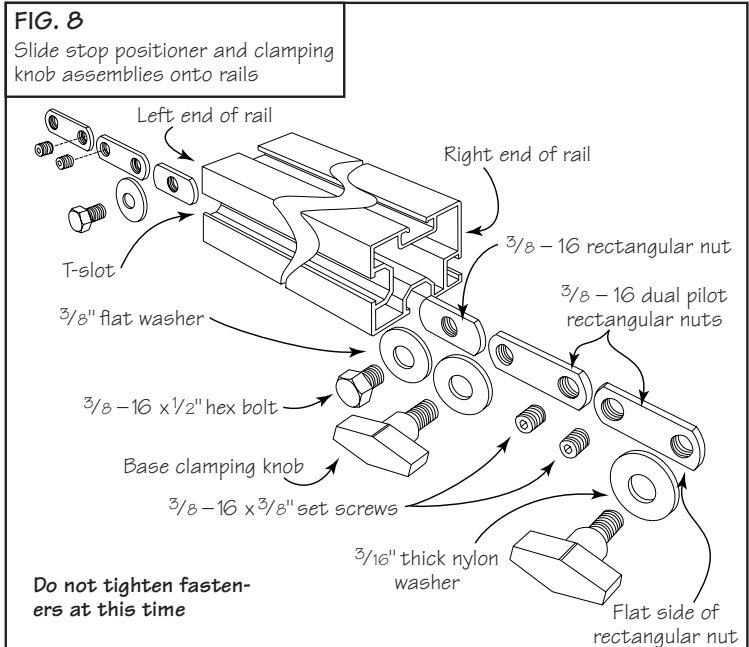

BASE MOUNT ASSEMBLY

Note: The base support bars used in the base mount assembly are designed for use with table saws having a front to back measurement of 27" to 28". If your table saw measures outside of these dimensions custom cut support bars are available.

1 Install panel between base support bars and attach one base clamp

Open the Base Mount and Fence Glide Hardware Pack. Place a #10 flat washer on each of (8) #10-32 x 1/2" phillips pan head screws. Place the screws through the holes in both base clamps and loosely attach the #10-32 hex nuts. Sandwich the panel between the two base support bars as shown in **Fig. 9** and **Detail 9A**, then slide one of the base clamps onto the base support bar ends, capturing the hex nuts in the T-slots. Leave about 1/4" between the support bar ends and the vertical surface on the base clamp. See **Detail 9B**. Tighten the screws. Set aside the remaining fasteners from the Base Mount and Fence Glide Hardware Pack for use in Steps 2 and 3 on page 8.

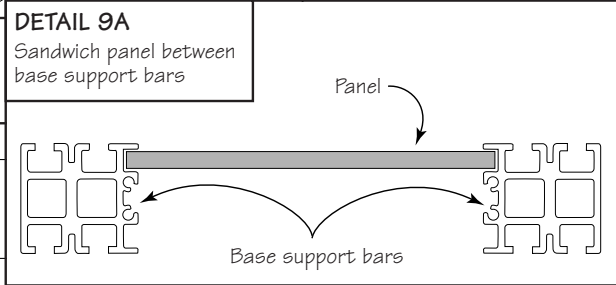
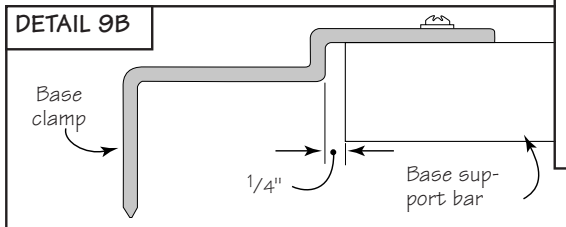
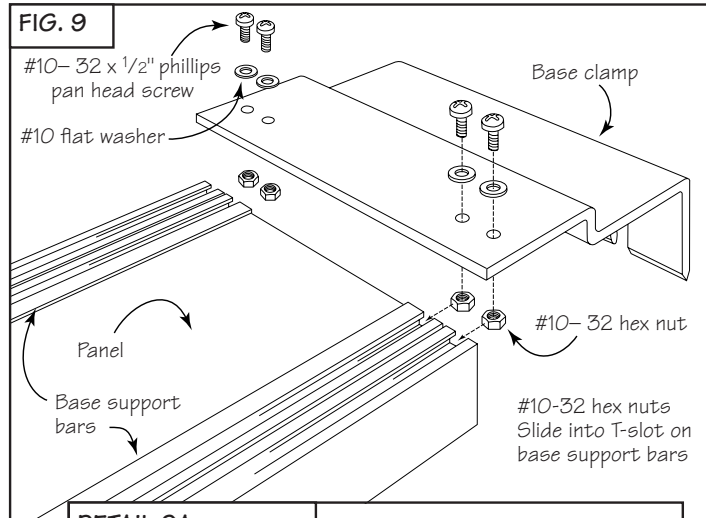

2 Attach INCRA Jig Ultra to base support bars and loosely attach remaining base clamp

Open the Ultra Mounting Hardware Pack. Place #10 washers on each of (4) #10-32 x 3/4" phillips pan head screws and insert through the slotted holes in the Ultra. Add a 1/4" thick nylon washer to each screw, then loosely thread on hex nuts. Place (2) #10-32 x 3/4" truss head screws through the two inside holes located in the middle of the Ultra's base. Do not place a #10 washer on the truss head screws. (Truss head screws have a larger head diameter than pan head screws.) Add a 1/4" thick nylon washer to the screws underneath the base and thread on hex nuts. Slide the hex nuts on all six screws into the T-slots on the base support bars. The screws through the slotted holes will fit into the outer T-slots. The truss head screws will fit into the inner T-slots. See **Fig. 10** and **Detail 10A**. The 1/4" nylon washers will hold the Ultra 1/4" above the support bars.

Center the Ultra on the base support bars' length. (Edge of Ultra should be about 10 5/8" from end of bars.) Use a square to align the Ultra base at 90° to the support bars and tighten the screws installed in the slotted holes only. **Do not tighten the truss head screws at this time.** Slide the hex nuts on the remaining base clamp into the T-slots on the support bars.

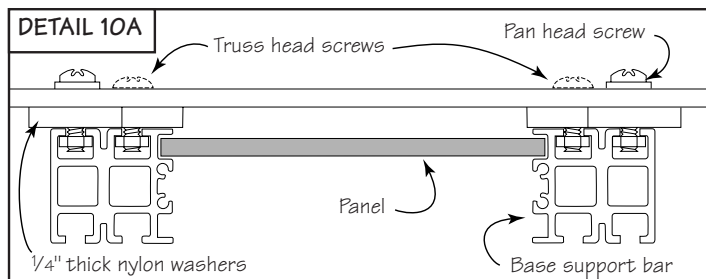
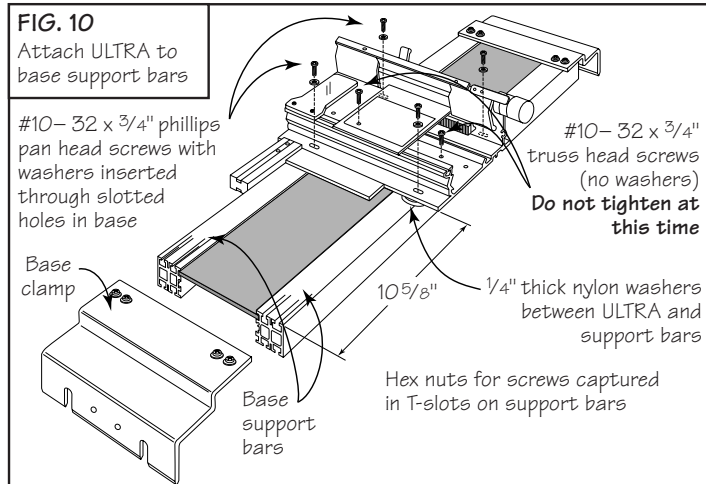

3 Align base mount assembly parallel to miter slot

Take the base mount assembly to the table saw and as you lower the base mount onto the rails, position the (4) clamping knob assemblies directly under the slots in the base clamps. Slide the base assembly along the rails to position the nearest support bar at 20" from the miter slot, **Fig. 11**. Take a measurement at both ends of the bar. Loosen the phillips head screws that hold the base clamps as necessary to align the bar parallel to the miter slot. Tighten the four base clamping knobs, then tighten all eight screws that secure the base clamps to the base support bars.

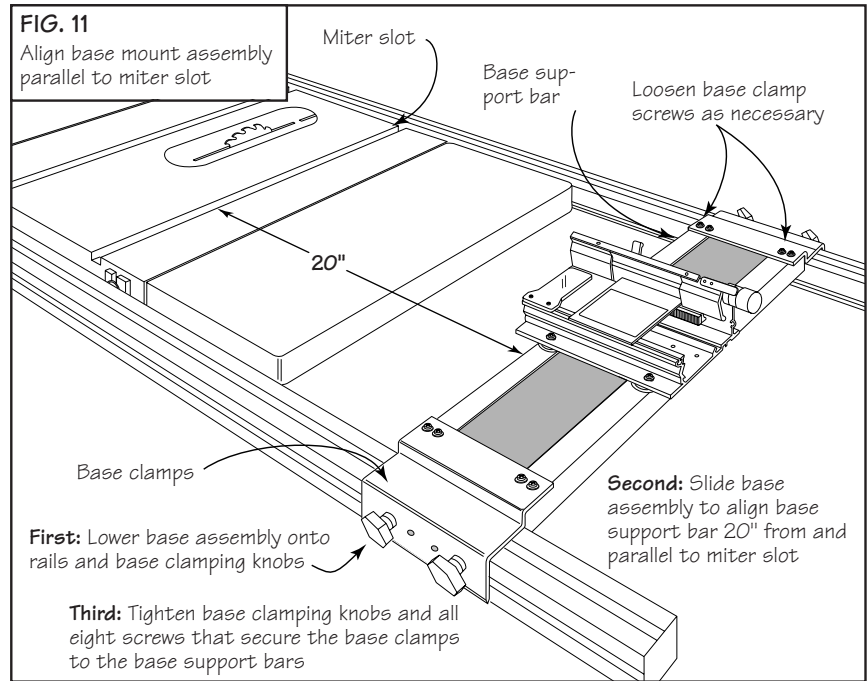

4 Set final base assembly position

Loosen the (4) base clamping knobs and slide the base assembly to locate the near side support bar at 30" from the saw blade. See **Fig. 12**. Tighten the clamping knobs in place. Using a 3/16" hex tool, tighten the (4) set screws through the holes located in the base clamps. Slide the (2) stop positioners up against the base clamps as shown and tighten the hex bolts. Should you ever need to remove the base assembly from your table saw, these stop positioners will allow you to return to the original setup in seconds.

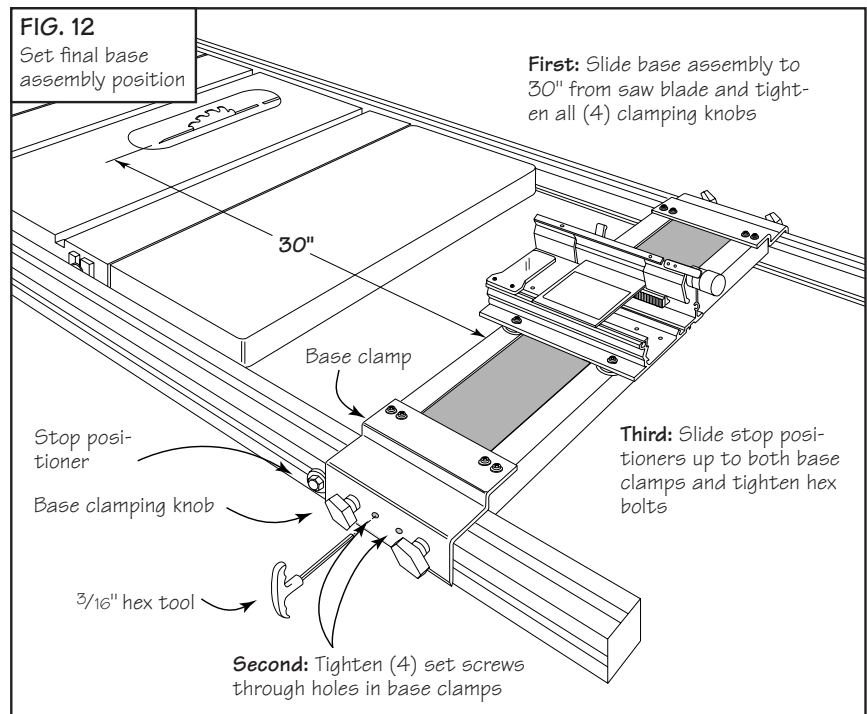

FENCE ASSEMBLY

Important: If you have not already done so, read the operations section of your INCRA Jig Ultra owner's manual (pages 6 and 7) to familiarize yourself with the clamping and micro adjust functions of the Ultra before continuing.

1 Slide Ultra carriage into base

Slide your Ultra's carriage into the base and position the fence mounting bracket approximately in line with the two nearest rail mounting brackets. Lock the carriage in place. See Fig. 13.

2 Loosely attach TS II fence

Place a 5/8" o.d. (gold) washer on each of (2) #10-32 x 1" phillips pan head screws and insert the screws through the holes in the back of the fence mounting bracket. Loosely attach the #10-32 rectangular nuts to the screws, then slide the fence onto the rectangular nuts as shown in Fig. 14. Position the end of the fence nearest to the operator about 3 1/2" in front of the table's edge. Do not tighten the fence mounting screws at this time.

3 Attach fence glides

Place one of the supplied 3/4" x 3" cardboard spacers under each end of the fence as shown in Fig. 15 and attach the two fence glides to the rear of the fence using the 1/4-20 x 1 1/2" socket head cap screws, 1/4" washers and 1/4-20 square nuts. See Detail 15A. The glide with the black thumbscrew mounts on the operator's side of the saw. Align the glides flush with the rails before tightening the fasteners. Remove and save the cardboard spacers.

4 Tighten fence mounting screws

Unlock the carriage and slide the fence about 15" away from the blade. Make sure the fence glides are still aligned flush with the rails, then tighten the two fence mounting screws. Take care not to raise or lower the fence mounting bracket as you tighten the screws.

5 Engage anti-lift rail hooks

Lock the carriage clamp, then turn the black thumbscrew on the front fence glide counter-clockwise to lower the rail hook into the T-slot on the rail. Look into the T-slot as you lower the hook. When the hook passes the lip on the T-slot, slide the black thumbscrew toward the table saw to position the hook under the lip. See Fig. 16. Now turn the thumbscrew clockwise to raise the hook. The hook can be adjusted to limit fence lift by turning the thumbscrew clockwise. **During cutting operations, always tighten the thumbscrew in addition to locking the carriage clamp to provide absolute lockdown of the fence position.**

To engage the rear rail hook, walk to the rear of the saw and using a 3/16" hex tool, lower the hook into the T-slot on the rail. Slide the fastener back to position the hook under the T-slot lip, then turn the fastener clockwise to adjust the lift limit. Allow the fence to lift no more than 1/32". **It is not necessary to tighten the rear rail hook before making a cut.**

CAUTION: Never adjust rear rail hook by reaching over the saw. If an adjustment must be made, turn off the saw and walk to the rear to make the adjustment.

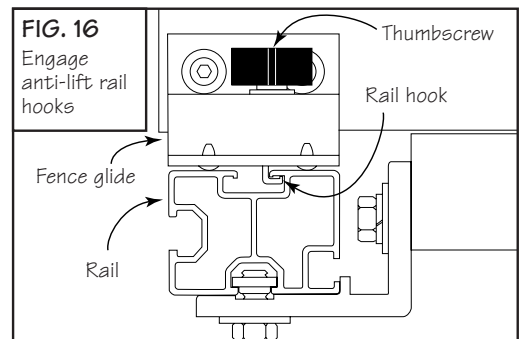
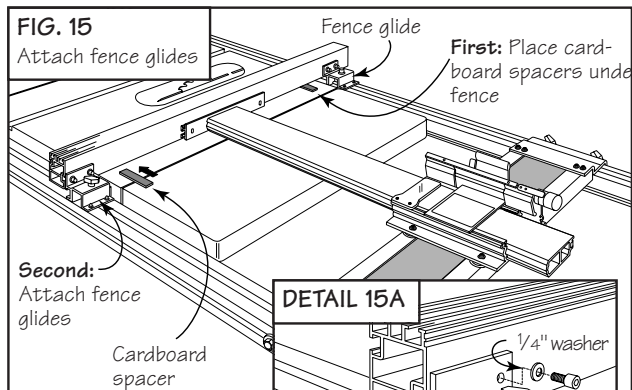
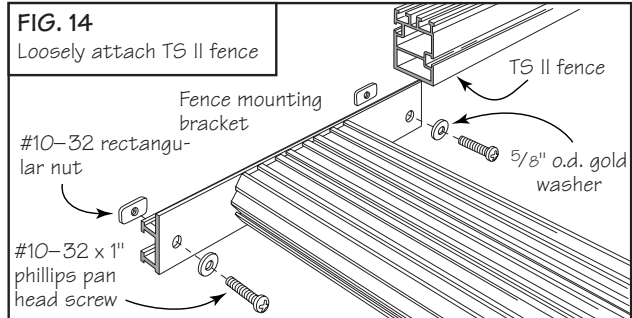
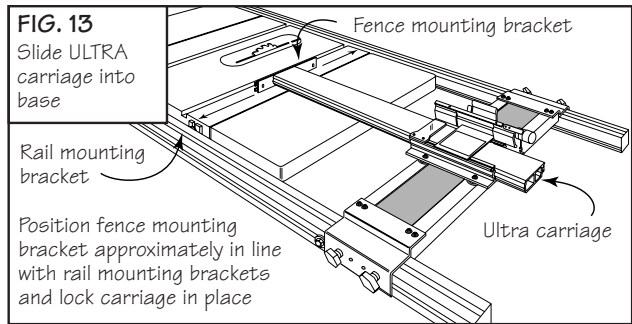

Note: When removing the TS II from your table saw, always disengage the rail hooks from the T-slot lip before lifting the TS II off the rails.

FINAL CALIBRATION

Important: As with any table saw fence, accurate calibration and alignment require that the saw blade be aligned parallel to the miter slots. If you are uncertain about your saw blade/miter slot alignment, consult your table saw's owner's manual for information on how to check and set this important alignment.

Calibration - Right Side of Saw Blade

1 Align fence parallel to miter slot and tighten Ultra's mounting screws

Unlock the carriage clamp, then slide the fence up to the nearest miter slot and clamp in place. Loosen the (4) screws that secure the Ultra's base to the base support bars and align the fence parallel to the miter slot. See Fig. 17. Make sure during this alignment that the fence glides remain flush with the rails. Retighten the (4) screws. Now unlock and slide the carriage forward far enough to allow access to the (2) truss head screws in the middle of the Ultra's base and tighten these in place.

Important: If it becomes necessary to realign the fence in the future, make sure to loosen all (6) base mounting screws.

2 Zero fence to saw blade

With the table saw unplugged, raise the saw blade about 2" and slide the fence forward until just before it contacts the blade (to within less than $\frac{1}{32}$ "). Place your Ultra in the micro adjust mode as described on page 7 of your Ultra's owner's manual and micro adjust the fence forward until it "kisses" the saw blade, Fig. 18. Release the micro adjust lever and lock the carriage in place.

Note: After micro adjusting, re-zero the scale on the micro adjust knob by rotating the scale (not the knob) to return to zero under the micro cursor.

3 Set scale position

With the Ultra still locked at the "zeroed" position set above, slide the middle (0"-16") scale in the scale slot to position 0" under the hairline cursor. Unlock and move the carriage to read 16" under the cursor, then lock the carriage in place. Now slide the shorter (16"-25") overlapping scale to also read 16" under the hairline cursor. See Fig 19. Take care not to move the longer scale when you slide the shorter, overlapping scale into place.

FIG. 17

Align fence parallel to miter slot and tighten ULTRA mounting screws

First: Loosen ULTRA mounting screws, align fence then retighten screws

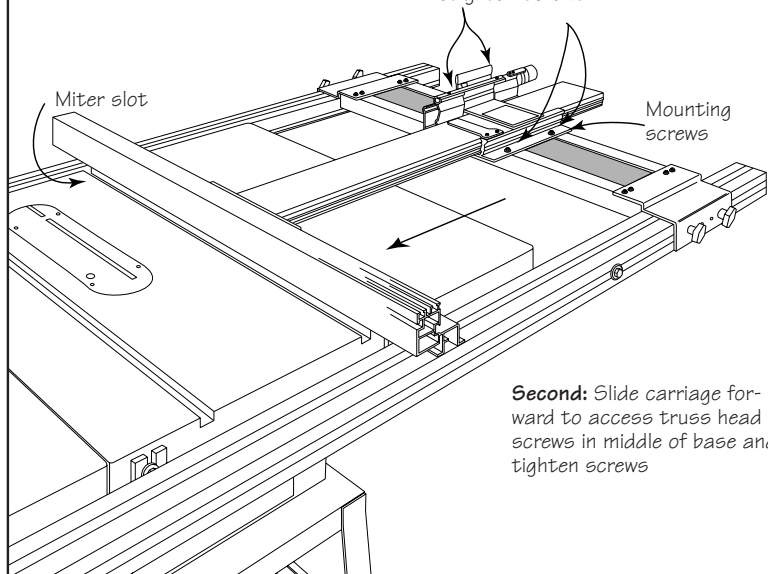

Second: Slide carriage forward to access truss head screws in middle of base and tighten screws

FIG. 18

Zero fence to saw blade

First: Slide fence forward to within less than $\frac{1}{32}$ " from saw blade

Second: Micro adjust fence forward until fence "kisses" the saw blade, then lock the carriage in place

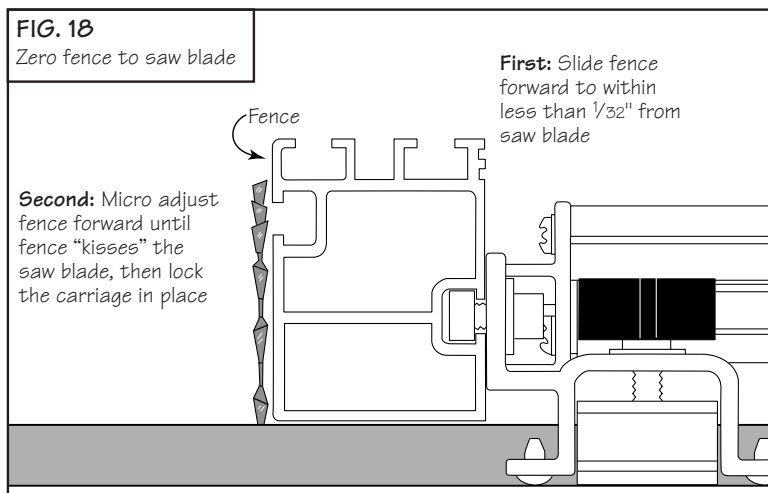
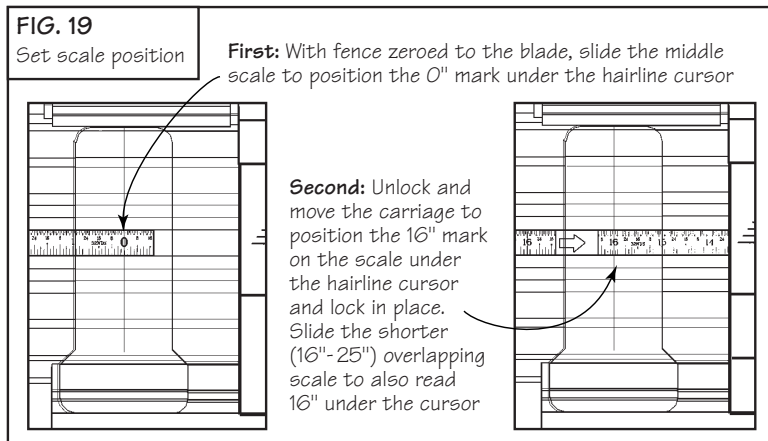

FIG. 19

Set scale position

First: With fence zeroed to the blade, slide the middle scale to position the 0" mark under the hairline cursor

Second: Unlock and move the carriage to position the 16" mark on the scale under the hairline cursor and lock in place. Slide the shorter (16"-25") overlapping scale to also read 16" under the cursor



Calibration - Left side of saw blade

Moving your TS II to the left side of the blade can be quite useful, especially on table saws which have a blade tilt to the right. This feature makes bevel cuts on opposing edges of a panel safe and easy since the blade tilts away from rather than toward the fence. The setup is easy.

Note: If your table saw blade tilts to the left, calibration on the left side of the blade is not necessary. Remove the (4) dual pilot rectangular nuts and stop positioners slid into the left end of the rail earlier.

1 Place Ultra on the rails to the left of saw blade

Unscrew the (4) base clamping knobs and thread the knobs into the dual pilot rectangular nuts slid into the left end of the rails in step 6 on page 5. Disengage the rail hooks from the T-slots on the rails and lift the Ultra off of the table. Carry the unit to the left end of your table saw and as you lower the base mount onto the rails, position the (4) clamping knob assemblies directly under the slots in the base clamps. Position the rear edge of the base mount assembly approximately flush with the rail ends and tighten the clamping knobs on the rear rail only, **Fig. 20**.

2 Align fence parallel to miter slot and tighten clamping knobs and set screws

Unlock carriage and slide the fence to the miter slot on your table saw. Align the fence parallel to the miter slot by shifting the base clamp on the front rail. Once the fence is set parallel to the miter slot, tighten all base clamping knobs. Then using a $\frac{3}{16}$ " hex tool, tighten the (4) set screws through the holes located in the base clamps, **Fig. 21**.

3 Zero fence to left side of saw blade

Unlock the carriage and move the fence to within less than $\frac{1}{32}$ " from the saw blade. Place the Ultra in micro adjust mode and micro adjust the fence forward until it "kisses" the saw blade, **Fig. 22**. After micro adjusting, release the micro adjust lever and lock the carriage in place.

Note: Whenever you return the Ultra to operation on the right side of the blade, remember to micro adjust the fence back to a zero reading on the micro adjust scale.

4 Set scale and stop positions

Slide the extra (0"-16") scale in the scale slot and position the 0" mark under the hairline cursor. Now slide the remaining (2) stop positioners up to the base clamps and tighten the hex bolts. Once these stops are set, you'll be able to return easily to your left hand setup anytime, **Fig. 23**.

Important: With right and left calibrations now complete, reinstall blade guard and all safety equipment removed previously. Raise the saw blade and tilt to 45° to check for clearance between the blade guard and the rear rail assembly. If the rear rail interferes with the blade guard, you must follow the instructions set out in the Blade Guard Adjustments section of this manual.

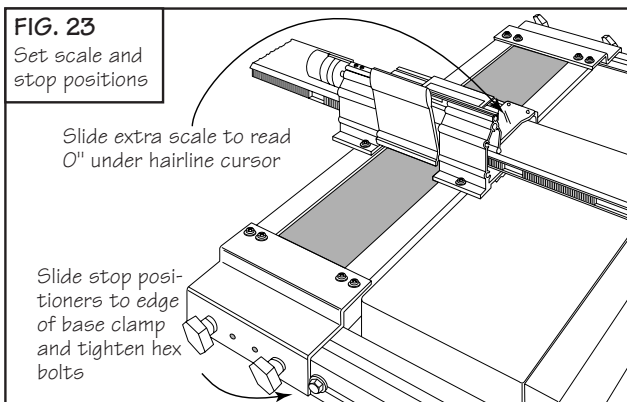
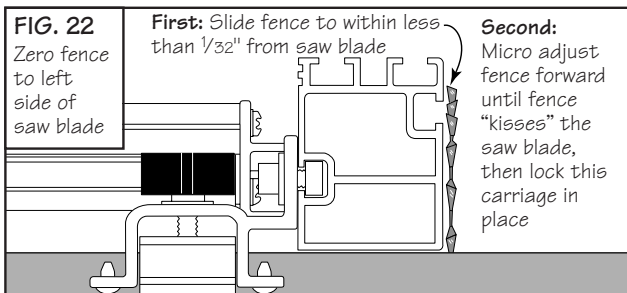
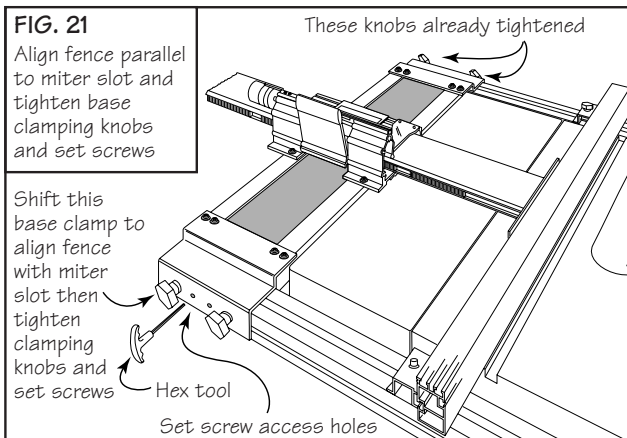
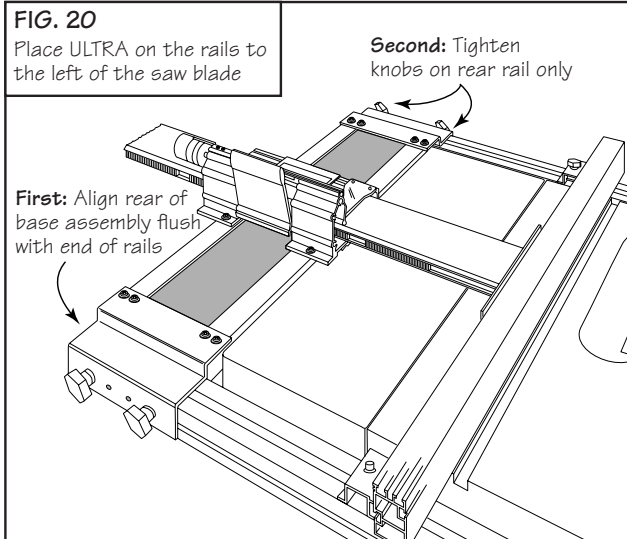

BLADE GUARD ADJUSTMENTS

If, after reinstalling the blade guard and tilting the motor, you find that the rear rail interferes with the blade guard, you must add the two remaining rail mounting brackets and split the rear rail to provide the necessary clearance as shown in **Fig. 24**. Begin by removing the base mount assembly. Loosen the bolts that secure the rear rail to the existing brackets and slide the rail off. Reinstall the blade guard, then locate the positions for the additional rail mounting brackets on either side of the blade guard. The mounting brackets should be placed as close as possible to the blade guard, but before drilling the mounting holes, make sure to check the positions for clearance when the blade is tilted to 45°. When you have found the mounting bracket locations, drill a $\frac{3}{8}$ " diameter hole in the center of each position. The center of the hole should be about $1\frac{1}{8}$ " below the table top.

Remove blade guard, then using $\frac{3}{8}$ -16 x $1\frac{1}{2}$ " hex bolts, nuts and washers, attach the extra mounting brackets loosely in place. Install the rail bolts as shown in **Fig. 2** on page 4, then slide the rear rail back into position. Tighten all rail mounting bolts, then tighten the two bolts that secure the brackets to your table saw. Use a hacksaw to make a cut through the rear rail about halfway between the two additional rail mounting brackets. Loosen the bolts that secure the rails to the brackets and slide the rails to create an opening large enough to reinstall the blade guard. See **Fig. 25**. Again, tilt the blade to 45° to check for clearance. Once the rail positions are established, sand or file the cut ends of the rails to remove any sharp edges. Tighten the bolts that secure the rails, then repeat the alignment and calibrations starting with Step 4 on page 7.

FIG. 24

Rear rail modification

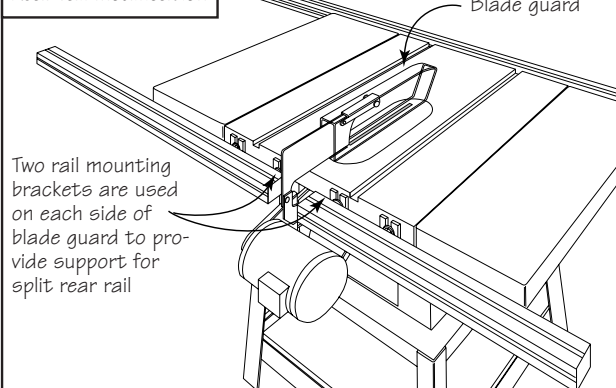
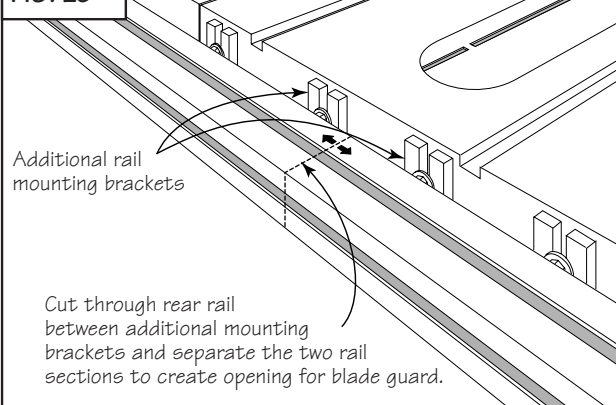

FIG. 25



EXTENSION TABLE

If you wish to add a $\frac{3}{4}$ " thick table board between the right hand extension wing of your table saw and the TS II base mount assembly, begin by making the wooden supports shown in **Fig. 26**. For the length of the support, measure the distance between your extension wing and the base mount assembly. Loosely attach the fasteners through the holes in the supports. Remove the base assembly from your saw, then slide the square nuts into the inside T-slots on each rail, **Detail 26A**. Cut a table board to fit and screw to the supports. The oversize holes in the support should allow range for positioning the table board flush with your table saw top.

FIG. 26

Table board support

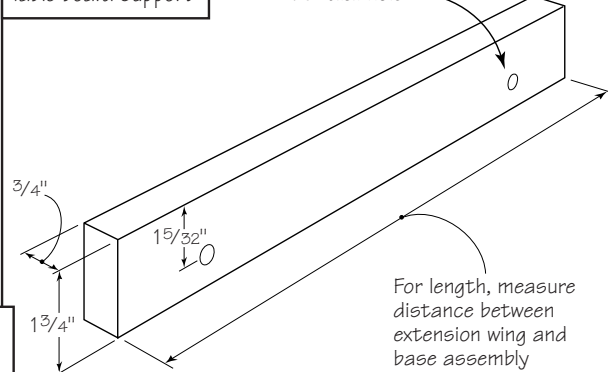

DETAIL 26A

Attaching table board support

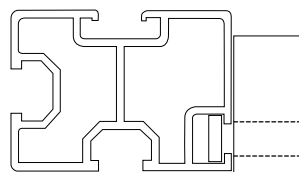

Fasteners required:
 (4) $\frac{1}{4}$ -20 x 1" hex bolts
 (4) $\frac{1}{4}$ " flat washers
 (4) $\frac{1}{4}$ -20 square nuts

Note: Above dimensions are for a $\frac{3}{4}$ " thick table board. Adjust hole position for different table board thickness

AUXILIARY FENCE MOUNTING

For some cutting operations, you may wish to add a wooden auxiliary fence to the front face of your TS II fence. A T-slot is provided for mounting the auxiliary fence using 1/4-20 mounting screws, washers, and square nuts. Drill and counterbore your wooden fence to recess the screw heads and capture the nuts in the T-slot as shown in **Fig. 27**. Hole centers should be located 1 3/4" from the bottom edge of the wooden fence. T-slots in the top of the fence are provided to attach hold downs or other user-made fixtures. Use 1/4-20 fasteners and square nuts for these T-slots as well.

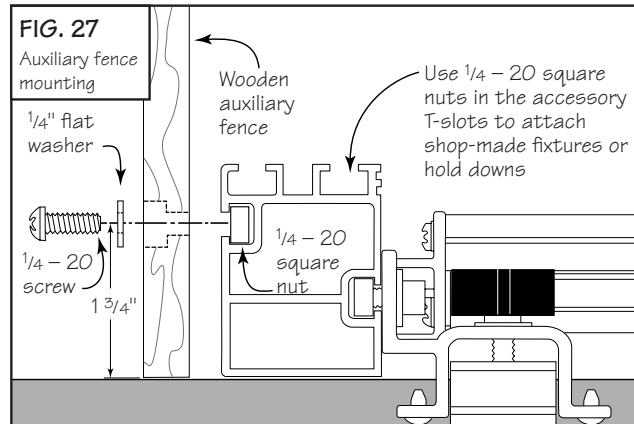

MAINTENANCE

Your TS II is designed to give many years of virtually maintenance-free operation. In fact, just keeping your TS II clean is all you need to do to keep the tool in top shape. Occasionally, remove the carriage from the base and brush or blow out any sawdust or debris that may have accumul-

ed. Use a toothbrush to clean the teeth on the INCRA racks on both the carriage and the base. A light application of paste wax to the top of the rails from time to time will keep the rails smooth and clean.

PRODUCT INFORMATION

For a product information update on the complete INCRA line of tools, please see your nearest dealer. If you are unable to locate a store nearby, or if you have trouble finding a particular product, we will honor your order directly.

For a product information brochure, call, write or fax to:
Taylor Design Group, Inc.
P.O. Box 810262, Dallas, Texas 75381
Tel: (972) 242-9975 Fax: (972) 242-9985
www.incra.com

WARRANTY

Taylor Design Group, Inc. warrants this product for one year from date of purchase. We will repair any defects due to faulty material or workmanship, or at our option, replace the product free of charge. Please return the failing component only, postage prepaid, along with a description of the problem to the address below. This warranty does not apply to parts which have been subjected to improper use, alteration, or abuse.

LIFETIME WARRANTY ON POSITIONING RACKS

If an INCRA positioning rack in this tool becomes damaged for ANY reason, Taylor Design Group will replace it free of charge for as long as you own your tool. Return the damaged rack, transportation prepaid, and allow 1 to 2 weeks for delivery.

NOTE:

Replacements cannot be sent unless damaged racks have been received by Taylor Design Group.

Made in America by:

Taylor Design Group, Inc. ■ P.O. Box 810262 ■ Dallas, Texas 75381

1097