

Incra[®]
*Incremental Micro
 Precision Table Saw Fence™*

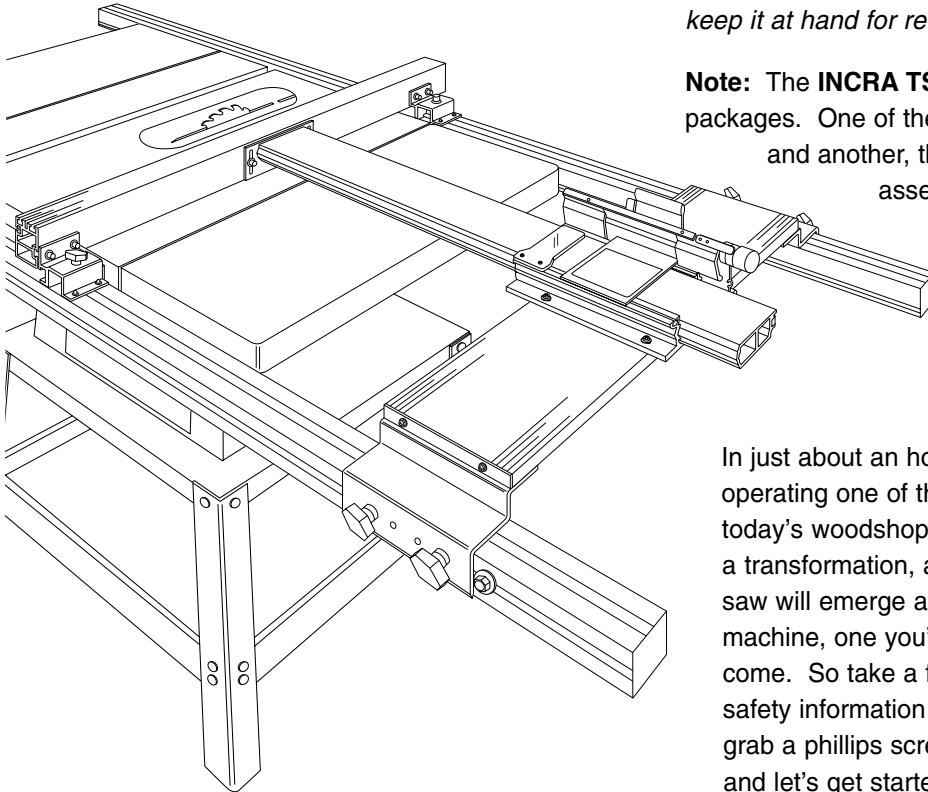

**The only table saw
 fence with *Automatic
 Positioning Control™***

OWNER'S MANUAL



Please read this owner's manual before use and keep it at hand for reference.

Note: The **INCRA TS III** system consists of three packages. One of the packages contains the rails and another, the base mount unit. These two assemblies are covered fully by this owner's manual. The third package contains the **INCRA Jig Ultra 32**. Read all of this TS III owner's manual and pages 2, 3, 6, 7, 18 and 19 of the Ultra owner's manual.

In just about an hour or so, you are going to be operating one of the most exciting new tools in today's woodshops. Your table saw will undergo a transformation, and what was once an average saw will emerge a precision woodworking machine, one you'll be proud of for years to come. So take a few minutes to read over the safety information and mounting instructions, then grab a phillips screwdriver and a set of wrenches and let's get started.

CONTENTS

| | |
|---|--|
| Safety 2 | Blade Guard Adjustments 11 |
| Fasteners and Hardware Lists 2 | Extension Table 11 |
| Rail Assembly 4 | Auxiliary Fence Mounting 12 |
| Base Mount Assembly 6 | Maintenance 12 |
| Fence Assembly 8 | Warranty 12 |
| Final Calibration 9 | |

SAFETY

Important safety instructions for using the INCRA TS III.

- Before using the INCRA TS III, read and follow all of the instructions and safety information in this manual.
- When using the INCRA TS III in conjunction with any other tool, first read and follow all instructions and safety information in that tool's owner's manual.
- Never let any part of the INCRA TS III interfere with another tool's safety guards or other safety equipment.
- Before using your INCRA TS III, make sure all mounting screws are tight and that the black clamping knobs are securely tightened to the rails.
- Always turn off the power and make sure that the blade is fully stationary before changing the setting on any part of the INCRA TS III.
- Always keep both hands behind the fence when moving the INCRA TS III to a new setting.
- Before making a cut, always make sure that the carriage clamp is fully engaged and that the rail hook thumbscrew is securely tightened.
- Use appropriate safety devices. Keep hands clear of the saw blade! Always use a push stick, rubber soled push block, or other safety devices to keep your hands safely away from the saw blade.
- Never let the saw blade come into contact with any part of the INCRA TS III or INCRA Jig Ultra.
- Wear safety glasses, hearing protection, and follow all normal shop safety practices.
- Never operate your table saw without a blade guard.

FASTENERS (actual size)

Mounting Bracket Hardware Pack

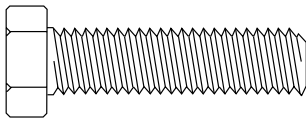

6 each
3/8 – 16 x 1 1/2"
hex bolt

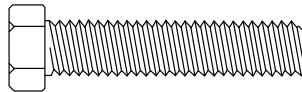

4 each
5/16 – 18 x 1 1/2"
hex bolt

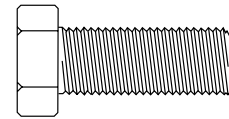

2 each
3/8 – 24 x 1"
hex bolt
(Delta Unisaw)

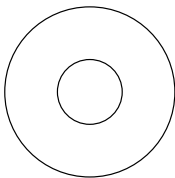

6 each
3/8"
flat washer

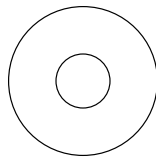

4 each
5/16"
flat washer

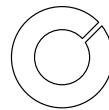

4 each
5/16"
lock washer

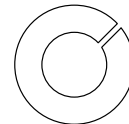

6 each
3/8"
lock washer

Note:

Extra hardware is provided in this pack to ensure compatibility with a wide variety of table saws. Only four of the bolts will be used in a typical installation.

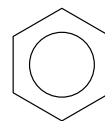

6 each
3/8 – 16
hex nut

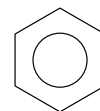

4 each
5/16 – 18
hex nut

Rail Hardware Pack

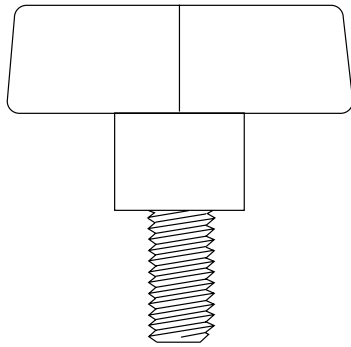

4 each
3/8 - 16 x 3/4"
clamping knob



4 each
3/8 - 16 x 3/8"
socket head set screw

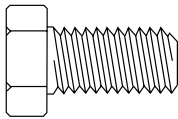

6 each
3/8 - 16 x 3/4"
hex bolt

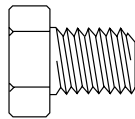

4 each
3/8 - 16 x 1/2"
hex bolt

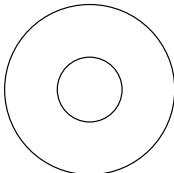

10 each
3/8"
flat washer

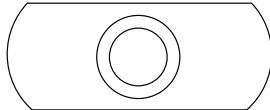

10 each
3/8 - 16
rectangular nut

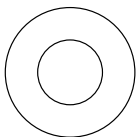

4 each
3/16"
thick nylon washer



4 each
3/8 - 16
dual pilot rectangular nut

Note:

Each hardware pack is labeled and bagged separately. Open each pack as it is called for in the instructions to simplify assembly.

Base Mount and Fence Glide Hardware Pack

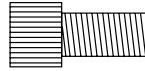

6 each
1/4 - 20 x 1/2"
socket head cap screw



8 each
#10 - 32 x 7/16"
phillips flat head screw

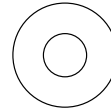

6 each
1/4"
flat washer



6 each
1/4 - 20
square nut



8 each
#10 - 32
hex nut

ULTRA Mounting Hardware Pack

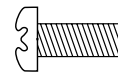

6 each
#10 - 32 x 1/2"
phillips pan head screw



6 each
#10 - 32
hex nut



6 each
#10
flat washer

RAIL ASSEMBLY

Unplug your table saw and remove the existing fence, including the front and rear support rails, mounting brackets, and the blade guard.

Note: The blade guard must be reinstalled after you have finished mounting the INCRA TS III to your table saw.

1 Attach mounting brackets

Attach (4) mounting brackets to the cast iron surface of your table saw using the supplied hardware. See **Fig. 1**. The *Mounting Bracket Hardware Pack* contains a variety of fasteners which will work with most table saws. Use the largest bolts in the pack that will fit your saw's existing mounting holes. If the holes in your table saw are threaded, use the bolt/lock washer/washer arrangement shown in **Detail 1A**. If the mounting holes are not threaded, use the bolt/washer/lock washer/nut arrangement shown in **Detail 1B**. Position the mounting brackets $\frac{1}{4}$ " below the table top as shown in **Details 1A** and **1B** and snug the fasteners to hold the brackets in place. **DO NOT TIGHTEN THE BOLTS AT THIS TIME.** (Discard any remaining fasteners from the *Mounting Bracket Hardware Pack*.)

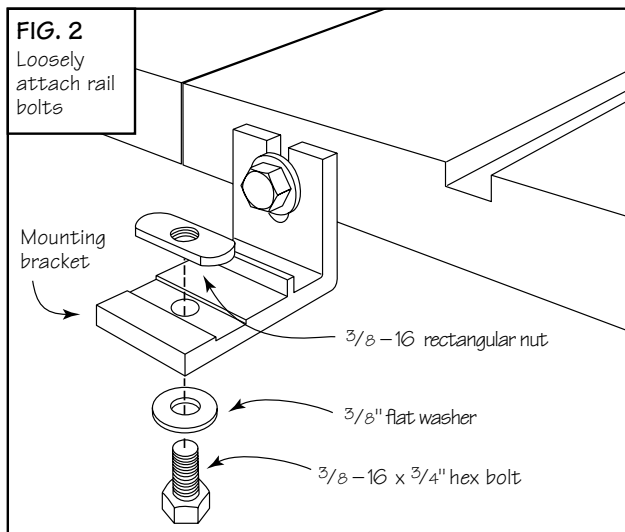

2 Loosely attach rail bolts

Open the *Rail Hardware Pack*. Add a $\frac{3}{8}$ " flat washer to each of (4) $\frac{3}{8}$ -16 x $\frac{3}{4}$ " hex bolts. Place the bolts through the holes in the mounting brackets and loosely attach the $\frac{3}{8}$ -16 rectangular nuts. See **Fig. 2** above.

3 Slide rails onto mounting brackets and tighten bolts

Carefully slide the rails onto the mounting brackets so that the rectangular nuts are captured in the T-slot on the bottom of the rail. **Fig. 3** shows the correct orientation for the front and back rails. Approximately center the length of the rails on your table saw and tighten the mounting bolts that secure the rails to the brackets.

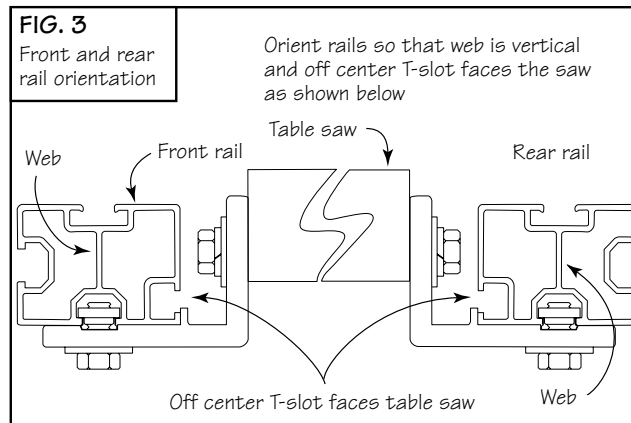
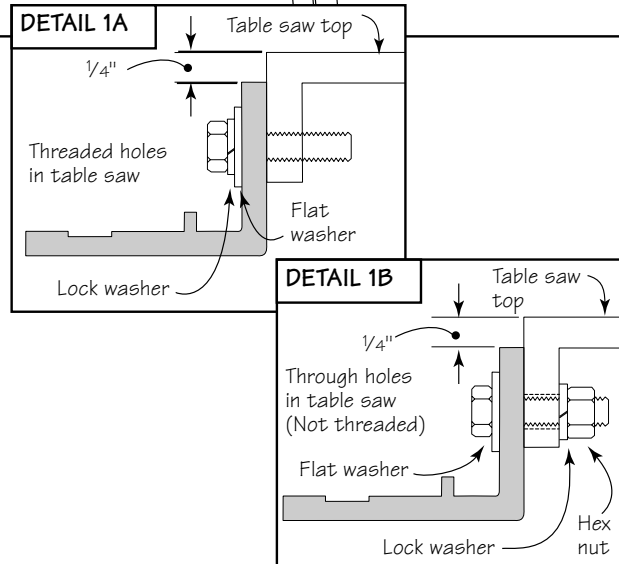
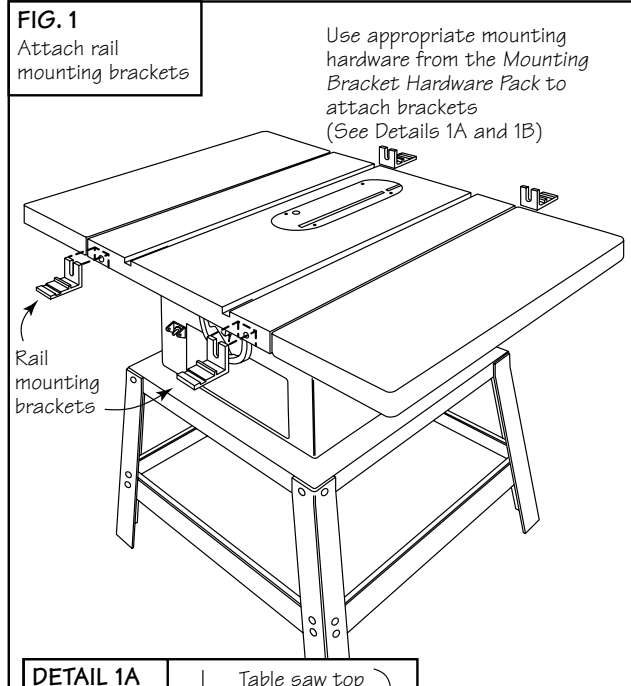

4 Set final mounting bracket position

Clamp the (2) TS III base clamps to the front rail as shown in **Fig. 4** and loosen the bolts that secure the mounting brackets to your table saw. The rail and mounting brackets will drop down until the base clamps touch the top of your saw, **Fig. 5**. This locates the final mounting bracket position. Tighten the bolts that secure the mounting brackets to your table saw. Repeat for the rear rail.

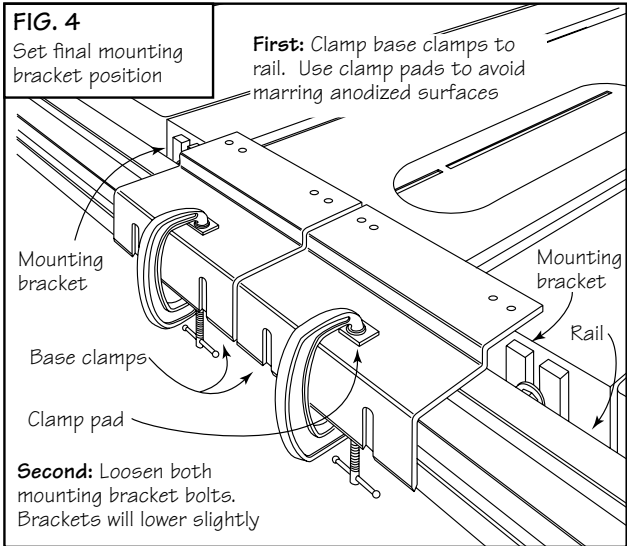
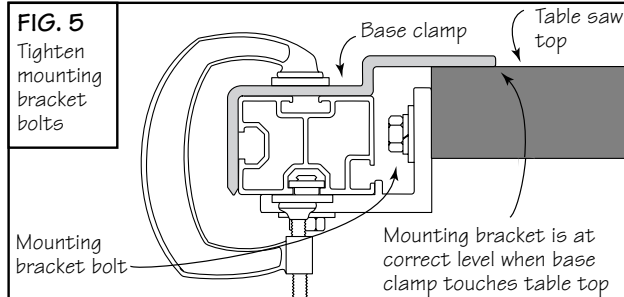

5 Set final rail position

Loosen the bolts that secure the rails to the mounting brackets and slide the rails so that they extend 7" beyond the left hand extension wing of your table saw as shown in **Fig. 6**. Push the rail against the short vertical leg on the mounting bracket and tighten the bolts that hold the rail in place. See **Fig. 7** below.

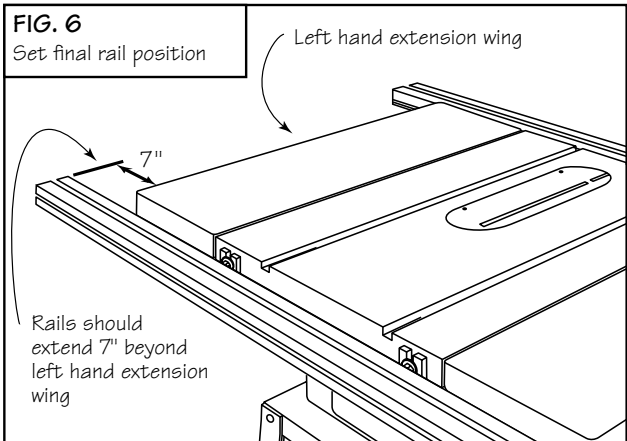
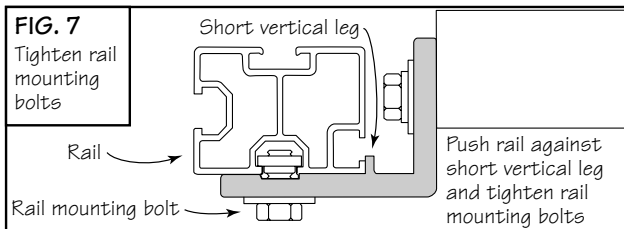

Custom Setups

The rail positions described above will provide support for the base of the TS III for work on either the left or right side of the blade. Left hand range is about 16" and right hand range is 31". These same rail positions will accommodate the optional 18" router table on the left or 24" router table on the right.

If you wish to customize the setup to suit your needs, just slide the rails left or right as necessary. Keep in mind that sliding the rails to the right subtracts from your range to the left and sliding the rails to the left subtracts from your range to the right.

6 Slide stop positioner and base clamping knob assemblies onto the rails

Base clamping knob - Add a $\frac{3}{16}$ " thick nylon washer to each of (4) base clamping knobs and loosely attach a $\frac{3}{8}$ -16 dual pilot rectangular nut. The flat side of the rectangular nut should face the knob. Thread a $\frac{3}{8}$ -16 x $\frac{3}{8}$ " set screw into the remaining hole on each rectangular nut. Slide the base clamping knob assemblies onto the right hand end of each rail as viewed from the operator's side of the table saw. Do not tighten set screws or knobs at this time. See **Fig. 8**.

Stop positioner - Add a $\frac{3}{8}$ " flat washer to each of (4) $\frac{3}{8}$ -16 x $\frac{1}{2}$ " hex bolts, then loosely attach a $\frac{3}{8}$ -16 rectangular nut. Slide one stop positioner into each end of both rails, capturing the rectangular nut in the T-slot as shown. Do not tighten bolts at this time.

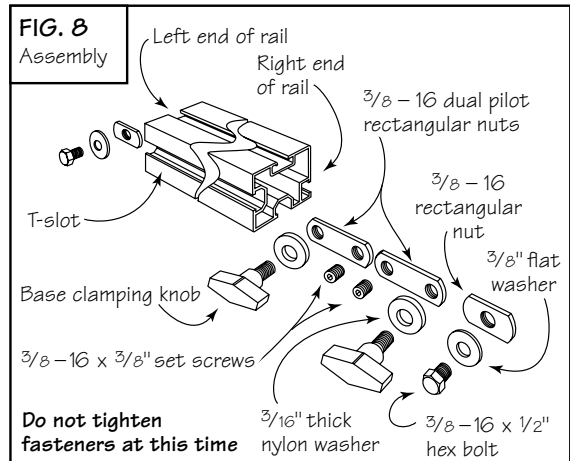

BASE MOUNT ASSEMBLY

Note: The base support panel used in the base mount assembly is designed for use with table saws having a front to back measurement of up to 28". If your table saw

measures greater than 28" a custom cut support panel is available. For details, e-mail us at questions@incra.com or call us at the number listed at the bottom of page 12.

1 Attach glide pads to underside of base clamps

Peel the adhesive backing from the glide pad and adhere to the base clamp as shown in **Fig. 9**. Repeat for remaining base clamp.

Note: Do not attach glide pads until after main rail installation has been completed. (See page 5, Figs. 4 and 5).

2 Remove endcaps from base support panel

See **Fig. 10** at right.

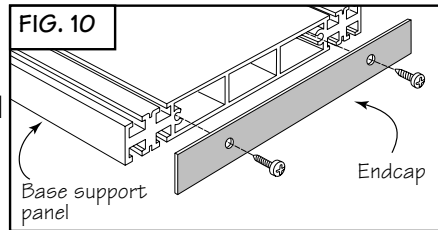

3 Attach one base clamp to end of base support panel

Open the *Base Mount & Fence Glide Hardware Pack*. Insert the (8) #10-32 x 7/16" phillips flat head screws in the countersunk holes of both base clamps and loosely thread on the #10-32 hex nuts. Slide the hex nuts on one of the base clamps into the (4) T-slots on the base panel. **Fig. 11**. Leave about 3/8" between the panel end and the vertical surface on the base clamp as shown in **Detail 11A** and tighten the screws. Set aside the remaining fasteners from the *Base Mount & Fence Glide Hardware Pack* for use in **Steps 2 and 3** on page 8.

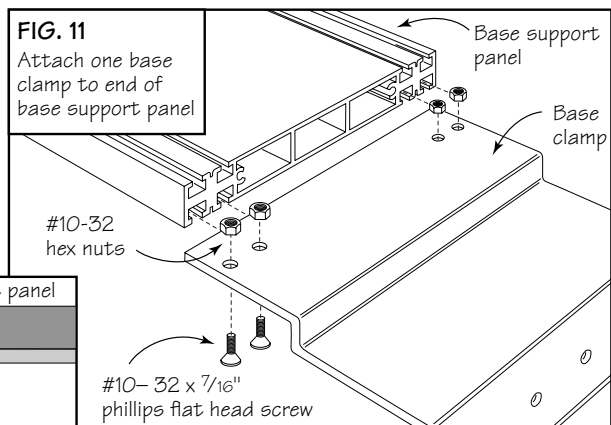
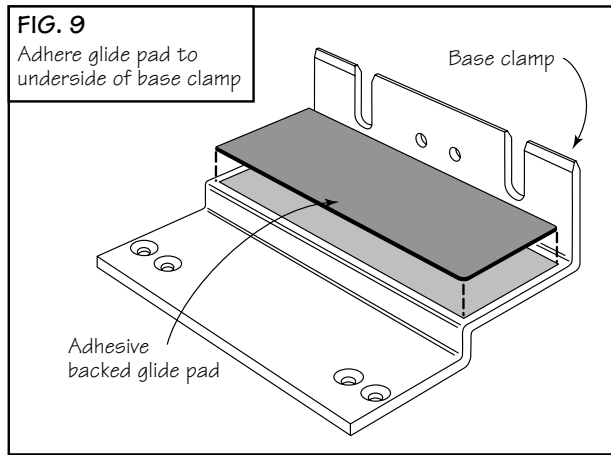
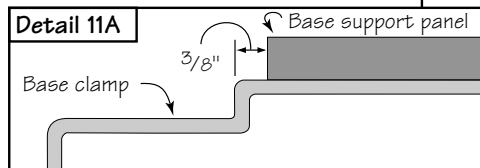

4 Attach the INCRA Jig Ultra to base support panel and loosely attach remaining base clamp

Open the *Ultra Mounting Hardware Pack*. Place #10 washers on each of the (6) #10-32 x 1/2" phillips pan head screws. Insert four of the screws through the slotted holes on the Ultra base and loosely thread a #10-32 hex nut onto each screw. Insert the remaining two screws through the two inside holes located in the middle of the Ultra's base and attach hex nuts. Slide the hex nuts on all six screws into the T-slots on the base support panel. The (4) screws/nuts in the slotted holes slide into the outer T-slots. The (2) screws/nuts inside the Ultra's base slide into the inner T-slots. See **Fig. 12** and **Detail 12A**.

Center the Ultra's base on the support panel. (Edge of Ultra should be about 10 5/8" from end of panel.) Use a square to align the Ultra base at 90° to the panel and tighten the screws installed in the slotted holes only. Do not tighten the two screws inside the Ultra's base at this time. Slide the hex nuts on the remaining base clamp into the T-slots on the support panel.

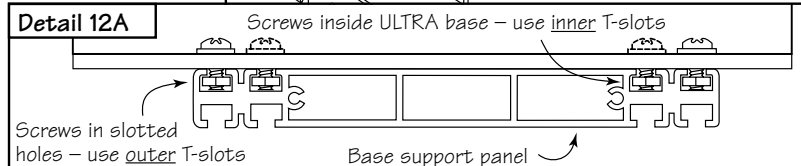
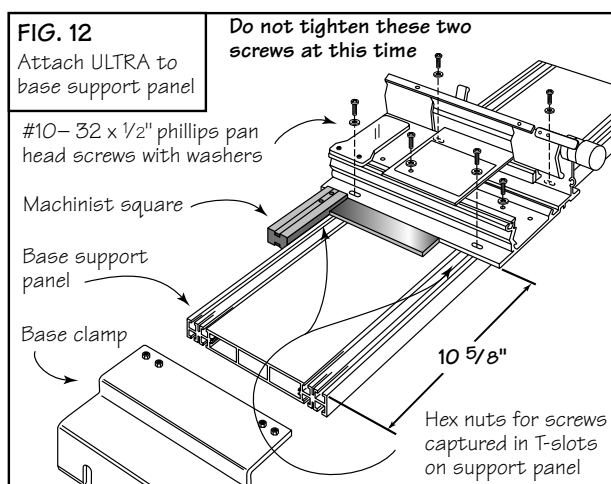

5 Align base mount assembly parallel to miter slot

Take the base mount assembly to the table saw and as you lower the base mount onto the rails, position the (4) clamping knob assemblies directly under the slots in the base clamps. Slide the base assembly along the rails to position the base support panel at 20" from the miter slot, **Fig. 13**. Take a measurement at both ends of the panel. Loosen the phillips head screws that hold the base clamps as necessary to align the panel parallel to the miter slot. Tighten the four base clamping knobs, then tighten all eight screws that secure the base clamps to the base support panel. Replace the base support panel end caps.

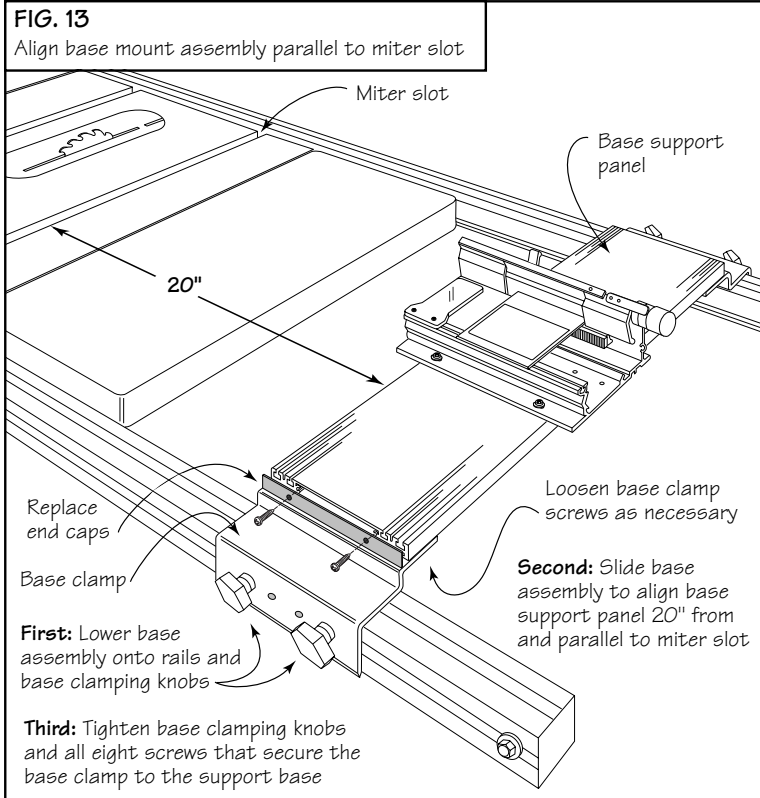

6 Set final base assembly position

Loosen the (4) base clamping knobs and slide the base assembly to locate the near side of the base support panel at 36" from the saw blade. See **Fig. 14**. Tighten the clamping knobs in place. Using a $\frac{3}{16}$ " hex tool, tighten the (4) set screws through the holes located in the base clamps. Slide the (2) stop positioners up against the base clamps as shown and tighten the hex bolts. Should you ever need to remove the base assembly from your table saw, these stop positioners will allow you to return to the original setup in seconds.

TIP

By loosening the (4) clamping knobs and set screws you can slide the base assembly to any position along the length of the rails – great for accessing a router table extension wing placed to the left of the blade.

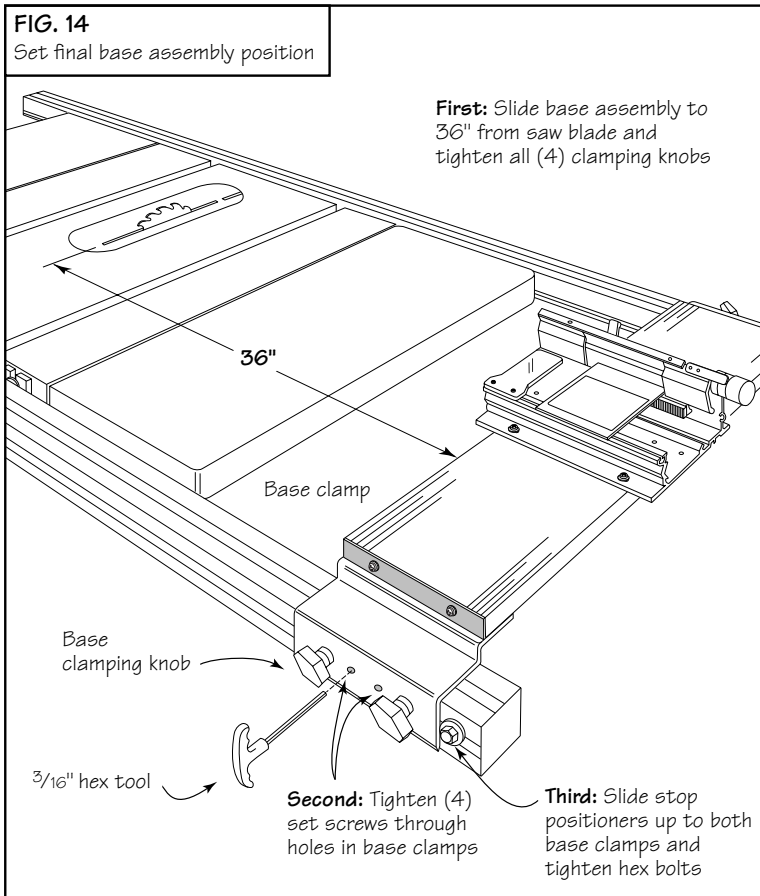

FENCE ASSEMBLY

Important: If you have not already done so, read the operations section of your INCRA Jig Ultra owner's manual (pages 6 and 7) to familiarize yourself with the clamping and micro adjust functions of the Ultra before continuing.

1 Slide Ultra carriage into base

Slide your Ultra's carriage into the base and position the fence mounting bracket approximately in line with the two nearest rail mounting brackets. Lock the carriage in place. See Fig. 15.

2 Loosely attach TS III fence

Place a 1/4" flat washer on each of (2) 1/4-20 x 1/2" socket head cap screws and insert the screws through the slotted holes in the back of the fence mounting bracket. Loosely attach the 1/4-20 square nuts to the screws, then slide the fence onto the square nuts as shown in Fig. 16. Position the end of the fence nearest to the operator about 3 1/2" in front of the table's edge. Do not tighten the fence mounting screws at this time.

3 Attach fence glides

Place one of the supplied 3/4" x 3" cardboard spacers under each end of the fence as shown in Fig. 17 and attach the two fence glides to the rear of the fence using (4) 1/4-20 x 1/2" socket head cap screws, 1/4" washers and 1/4-20 square nuts. See Detail 17A. The glide with the black thumbscrew mounts on the operator's side of the saw. Align the glides flush with the rails before tightening the fasteners. Remove and save the cardboard spacers.

4 Tighten fence mounting screws

Unlock the carriage and slide the fence about 20" away from the blade. Make sure the fence glides are still aligned flush with the rails, then tighten the two fence mounting screws. Take care not to raise or lower the fence mounting bracket as you tighten the screws.

5 Engage anti-lift rail hooks

Lock the carriage clamp, then turn the black thumbscrew on the front fence glide counterclockwise to lower the rail hook into the T-slot on the rail. Look into the T-slot as you lower the hook. When the hook passes the lip on the T-slot, slide the black thumbscrew toward the table saw to position the hook under the lip. See Fig. 18. Now turn the thumbscrew clockwise to raise the hook. The hook can be adjusted to limit fence lift by turning the thumbscrew clockwise.

During cutting operations, always tighten the thumbscrew in addition to locking the carriage clamp to provide absolute lockdown of the fence position.

To engage the rear rail hook, walk to the rear of the saw and using a 3/16" hex tool, lower the hook into the T-slot on the rail. Slide the fastener back to position the hook under the T-slot lip, then turn the fastener clockwise to adjust the lift limit. Allow the fence to lift no more than 1/32". **It is not necessary to tighten the rear rail hook before**

CAUTION: Never adjust rear rail hook by reaching over the saw. If an adjustment must be made, turn off the saw and walk to the rear to make the adjustment.

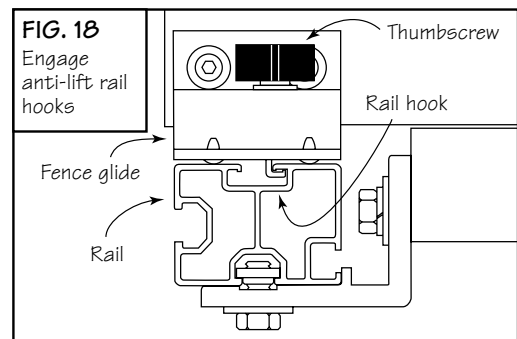
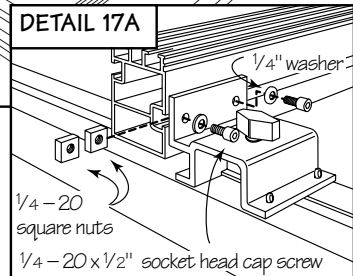
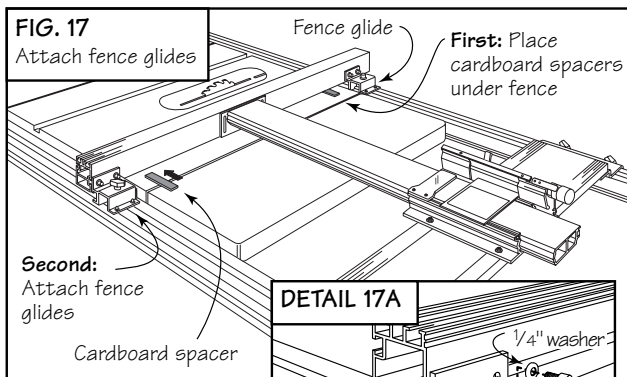
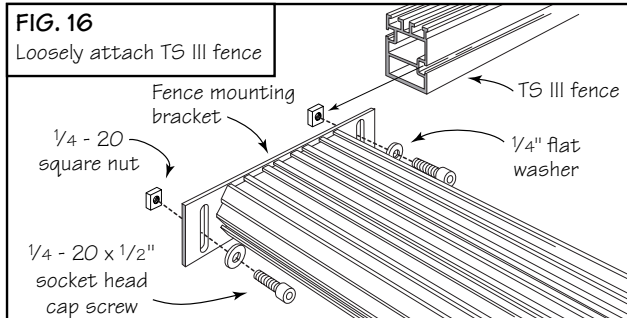
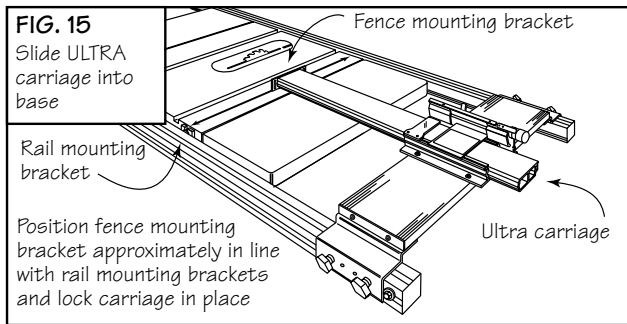

NOTE: When removing the TS III from your table saw, always disengage the rail hooks from the T-slot lip before lifting the TS III off the rails.

FINAL CALIBRATION

Important: As with any table saw fence, accurate calibration and alignment require that the saw blade be aligned parallel to the miter slots. If you are uncertain about your saw blade/miter slot alignment, consult your table saw's owner's manual for information on how to check and set this important alignment.

Calibration – Right side of saw blade

1 Align fence parallel to miter slot and tighten Ultra's mounting screws

Unlock the carriage clamp, then slide the fence up to the nearest miter slot and clamp in place. Loosen the (4) screws that secure the Ultra's base to the base support bars and align the fence parallel to the miter slot. See Fig. 19. Make sure during this alignment that the fence glides remain flush with the rails. Retighten the (4) screws. Now unlock and slide the carriage forward far enough to allow access to the (2) phillips head screws in the middle of the Ultra's base and tighten these in place.

Important: If it becomes necessary to realign the fence in the future, make sure to loosen all (6) base mounting screws.

2 Zero fence to saw blade

With the table saw unplugged, raise the saw blade about 2" and slide the fence forward until just before it contacts the blade (to within less than $\frac{1}{32}$ "). Place your Ultra in the micro adjust mode as described on page 7 of your Ultra's owner's manual and micro adjust the fence forward until it "kisses" the saw blade, Fig. 20. Release the micro adjust lever and lock the carriage in place.

Note: After micro adjusting, re-zero the scale on the micro adjust knob by rotating the scale (not the knob) to return to zero under the micro cursor.

3 Set scale position

With the Ultra still locked at the "zeroed" position set above, lift one end of the stainless steel scale from the magnetic track and slide the scale to position 0" under the hairline cursor. Fig. 21. Lower the scale back onto the magnetic track. If you want, you can also slide the two-piece lexan scale to agree with the stainless steel scale. Make sure the overlapping ends of the scales are aligned at 16".

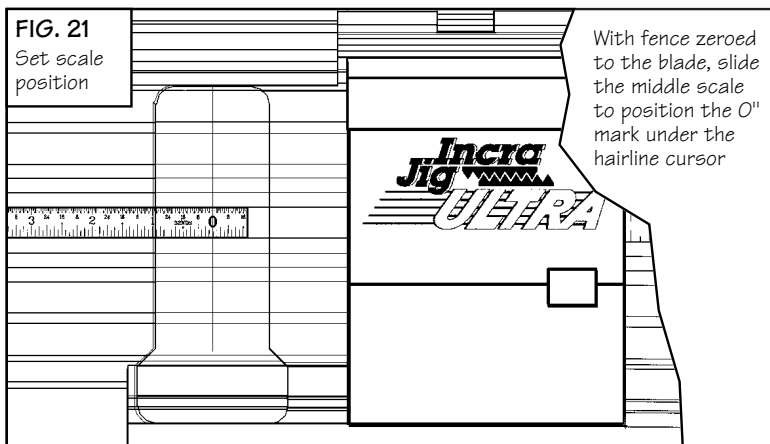
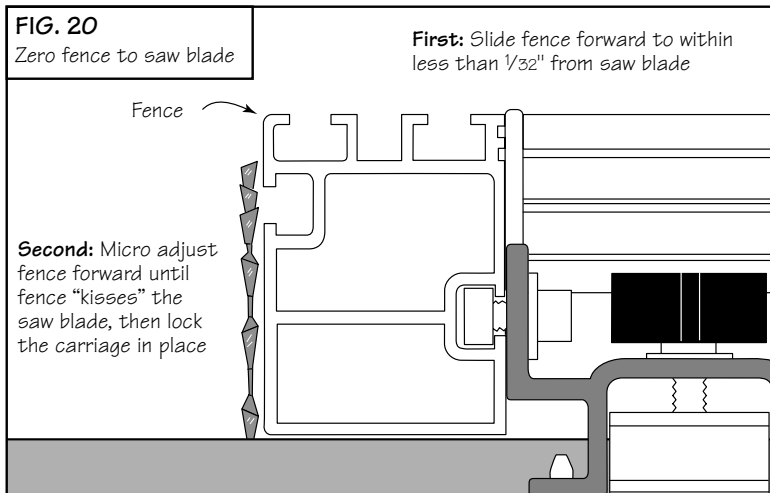
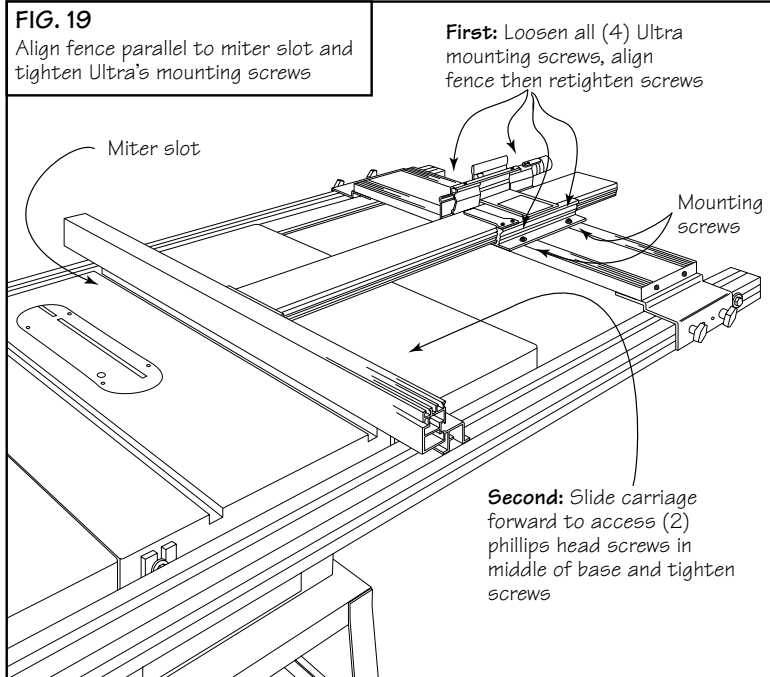

Calibration - Left side of saw blade

Moving your TS III to the left side of the blade can be quite useful, especially on table saws which have a blade tilt to the right. This feature makes bevel cuts on opposing edges of a panel safe and easy since the blade tilts away from rather than toward the fence. The setup is easy.

Note: If your table saw blade tilts to the left, calibration on the left side of the blade is not necessary.

1 Reverse Ultra's position and slide to left end of rails

Loosen the (4) base clamping knobs and the (4) set screws that secure the base assembly to the rails and slide the entire base assembly and Ultra to about mid-length along the rails. Lift the base assembly and Ultra off of the rails. Turn the base assembly and Ultra so the fence faces the opposite direction and place back onto the rails. (*Remember to always disengage, then re-engage the fence hooks when converting to left hand usage.*) Continue sliding the unit to the left to position the base assembly about 1" from the ends of the rails. Tighten the clamping knobs on the rear rail only.

Fig. 22. The two stop positioners installed earlier should be located at the end of the rails.

2 Align fence parallel to miter slot and tighten clamping knobs and set screws

Unlock the carriage and slide the fence to the miter slot on your table saw. Align the fence parallel to the miter slot by shifting the base clamp on the front rail. Once the fence is set parallel to the miter slot, tighten all base clamping knobs. Then using a $\frac{3}{16}$ " hex tool, tighten the (4) set screws through the holes located in the base clamps, **Fig. 23.**

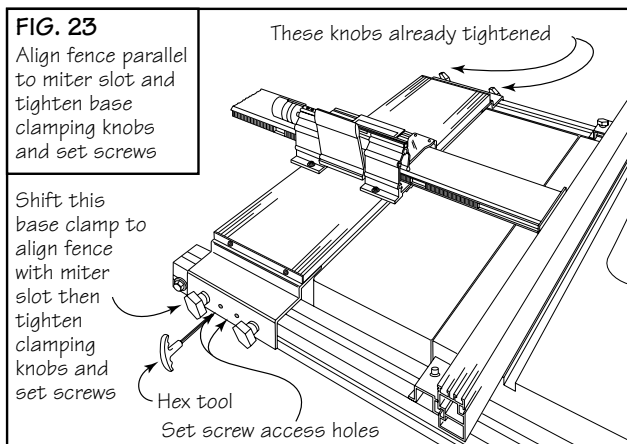
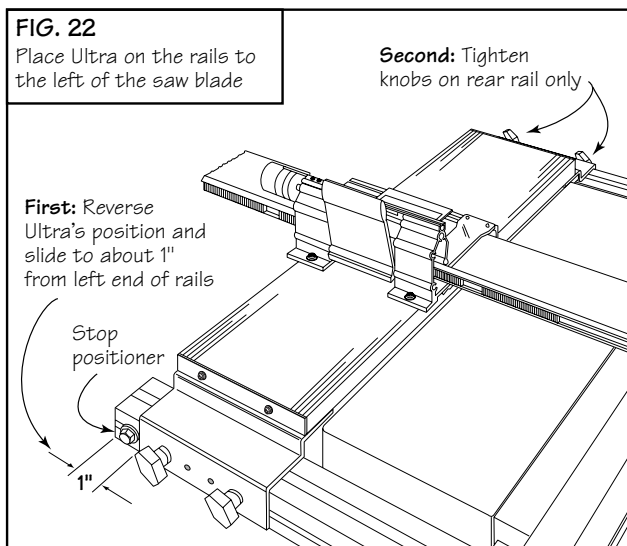

3 Zero fence to left side of saw blade

Unlock the carriage and move the fence to within less than $\frac{1}{32}$ " from the saw blade. Place the Ultra in micro adjust mode and micro adjust the fence forward until it "kisses" the saw blade, **Fig. 24.** After micro adjusting, release the micro adjust lever and lock the carriage in place.

Note: Whenever you return the Ultra to operation on the right side of the blade, remember to micro adjust the fence back to a zero reading on the micro adjust scale.

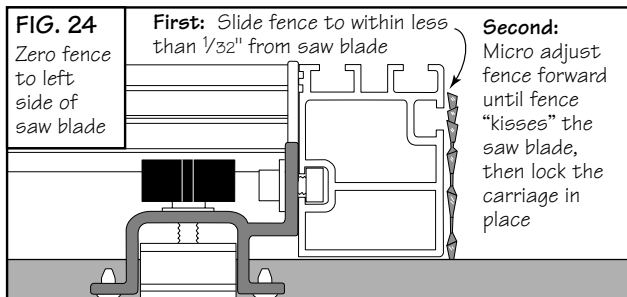

4 Set scale and stop positions

Slide the extra (0"-16") scale in the scale slot and position the 0" mark under the hairline cursor. Now slide the (2) stop positioners up to the base clamps and tighten the hex bolts. Once these stops are set, you'll be able to return easily to your left hand setup anytime, **Fig. 25.**

Important: With right and left calibrations now complete, reinstall blade guard and all safety equipment removed previously. Raise the saw blade and tilt to 45° to check for clearance between the blade guard and the rear rail assembly. If the rear rail interferes with the blade guard, you must follow the instructions set out in the *Blade Guard Adjustments* section of this manual.

INCRA Woodworking Tools & Precision Rules

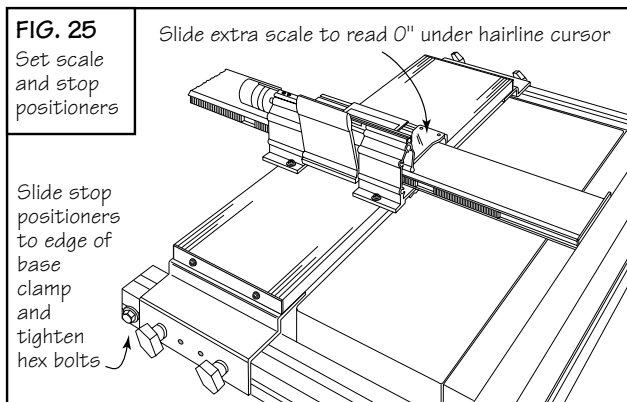

BLADE GUARD ADJUSTMENTS

If, after reinstalling the blade guard and tilting the motor, you find that the rear rail interferes with the blade guard, you must add the two remaining rail mounting brackets and split the rear rail to provide the necessary clearance as shown in **Fig. 26**. Begin by removing the base mount assembly. Loosen the bolts that secure the rear rail to the existing brackets and slide the rail off. Reinstall the blade guard, then locate the positions for the additional rail mounting brackets on either side of the blade guard. The mounting brackets should be placed as close as possible to the blade guard, but before drilling the mounting holes, make sure to check the positions for clearance when the blade is tilted to 45°. When you have found the mounting bracket locations, drill a $\frac{3}{8}$ " diameter hole in the center of each position. The center of the hole should be about $1\frac{1}{8}$ " below the table top.

Remove blade guard, then using $\frac{3}{8}$ "–16 x $1\frac{1}{2}$ " hex bolts, nuts and washers, attach the extra mounting brackets loosely in place. Install the rail bolts as shown in **Fig. 2** on page 4, then slide the rear rail back into position. Tighten all rail mounting bolts, then tighten the two bolts that secure the brackets to your table saw. Use a hacksaw to make a cut through the rear rail about halfway between the two additional rail mounting brackets. Loosen the bolts that secure the rails to the brackets and slide the rails to create an opening large enough to reinstall the blade guard. See **Fig. 27**. Again, tilt the blade to 45° to check for clearance. Once the rail positions are established, sand or file the cut ends of the rails to remove any sharp edges. Tighten the bolts that secure the rails, then repeat the alignment and calibrations starting with **Step 6** on page 7.

FIG. 26
Rear rail modification

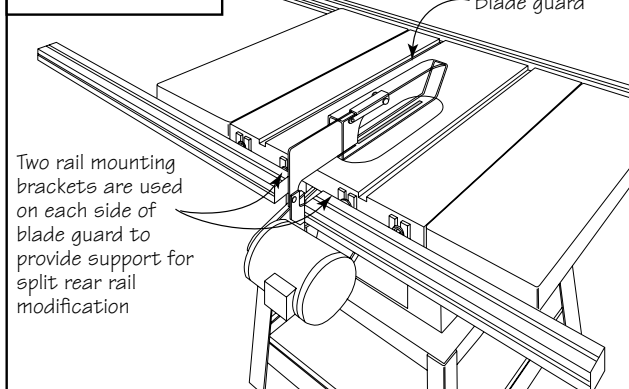
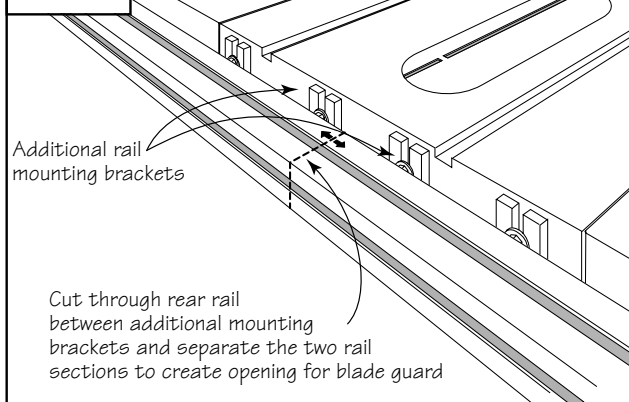

FIG. 27



EXTENSION TABLE

If you wish to add a $\frac{3}{4}$ " thick table board between the right hand extension wing of your table saw and the TS III base mount assembly, begin by making two of the wooden supports like the one shown in **Fig. 28**. For the length of the support, measure the distance between your extension wing and the base mount assembly. Loosely attach the fasteners through the holes in the supports. Remove the base assembly from your saw, then slide the square nuts into the inside T-slots on each rail, **Detail 28A**. Cut a table board to fit and screw to the supports. The oversize holes in the support should allow range for positioning the table board flush with your table saw top.

FIG. 28
Table board support

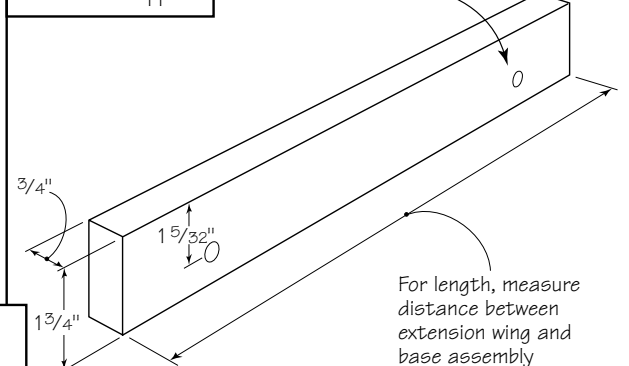

DETAIL 28A

Attaching table board support

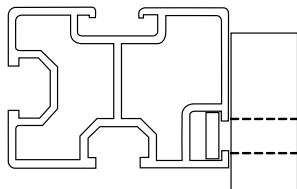

Fasteners required:

- (4) $\frac{1}{4}$ "–20 x 1" hex bolts
- (4) $\frac{1}{4}$ " flat washers
- (4) $\frac{1}{4}$ "–20 square nuts



AUXILIARY FENCE MOUNTING

For some cutting operations, you may wish to add a wooden auxiliary fence to the front face of your TS III fence. A T-slot is provided for mounting the auxiliary fence using 1/4–20 mounting screws, washers, and square nuts. Drill and counterbore your wooden fence to recess the screw heads and capture the nuts in the T-slot as shown in **Fig. 29**. Hole centers should be located 1 3/4" from the bottom edge of the wooden fence. T-slots in the top of the fence are provided to attach hold downs or other user-made fixtures. Use 1/4–20 fasteners and square nuts for these T-slots as well.

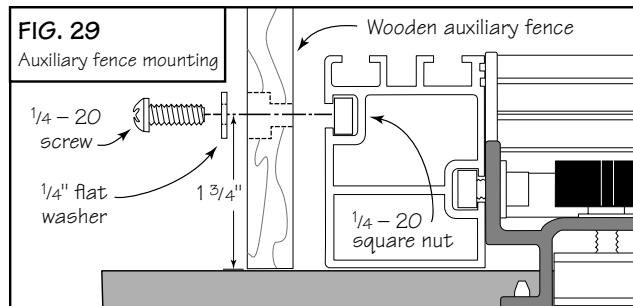

TIP

Floating Stops

Included with your TS III package you'll find a pair of "L" shaped brackets with mounting hardware. These stops mount to the bottom T-slot on the rails and are used when you want to set stop positions for the base assembly anywhere between the fixed left or right hand stops located on the sides of the rails.

One reason for a mid-range stop position might be to provide a single position for the base assembly where one could access both the saw blade and a left hand router table extension wing. Such a setup would provide about 15"-16" of range at the table saw function and up to 30" of travel for the router function. To install the stops, place a washer on each of the (2) 3/8 - 16 x 1/2" hex bolts. Insert the bolt through the hole in the stop and loosely thread on the rectangular nut. Slide the nut into the bottom T-slot

from the right end of each rail. (See **Fig. 30**). After positioning the ULTRA along the rails at the desired location, slide the floating stops up to the base clamps and tighten the bolts.

Once positioned, you can still slide the base assembly past the stops if necessary by first disengaging the fence hooks and loosening the (4) base clamp knobs then lifting the base assembly just enough to clear the stops as you slide the base assembly forward

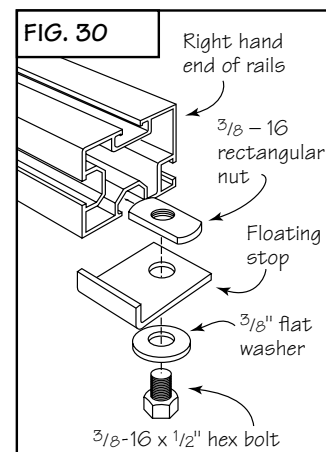

MAINTENANCE

Your TS III is designed to give many years of virtually maintenance-free operation. In fact, just keeping your TS III clean is all you need to do to keep the tool in top shape. Occasionally, remove the carriage from the base and brush or blow out any sawdust or debris that may have

accumulated. Use a toothbrush to clean the teeth on the INCRA racks on both the carriage and the base. A light application of paste wax to the top of the rails from time to time will keep the rails smooth and clean.

WARRANTY

Taylor Design Group, Inc. warrants this product for one year from date of purchase. We will repair any defects due to faulty material or workmanship, or at our option, replace the product free of charge. Please return the failing component only, postage prepaid, along with a description of the problem to the address below. This warranty does not apply to parts which have been subjected to improper use, alteration, or abuse.

LIFETIME WARRANTY ON POSITIONING RACKS

If an INCRA positioning rack in this tool becomes damaged for ANY reason, Taylor Design Group will replace it free of charge for as long as you own your tool. Return the damaged rack, transportation prepaid, and allow 2 weeks for delivery.

Note: Replacements cannot be sent unless damaged racks have been received by Taylor Design Group.

05/01

Made in America by:

Taylor Design Group, Inc. • P.O. Box 810262, Dallas, Texas 75381 • Tel: (972) 242-9975 • Fax: (972) 242-9985 • www.incra.com
Printed in the U.S.A. © 1996-2001, Taylor Design Group, Inc. INCRA is a registered trademark of Taylor Design Group, Inc.